

**BROOKVENT™**

# BMV PRO EC ROOF FANS



# Table of contents

## BMV PRO EC roof fans with horizontal air discharge

<b>BMV PRO 1.3</b> with EC motor	4
<b>BMV PRO 1.9</b> with EC motor	6
<b>BMV PRO 2.2</b> with EC motor	8
<b>BMV PRO 2.5</b> with EC motor	10

## BMV PRO EC roof fans with vertical air discharge

<b>BMV PRO 1.3 Vertical</b> with EC motor	14
<b>BMV PRO 1.9 Vertical</b> with EC motor	16
<b>BMV PRO 2.2 Vertical</b> with EC motor	18
<b>BMV PRO 2.5 Vertical</b> with EC motor	20

## Accessories

CSR-B EC W controller, CSR-B EC Zero Plus W controller, CSR-B EC NFC W	24
BR-S 1/010 potentiometer	25
BR-2/010 potentiometer	26
BR-TWIN 1-010 EC potentiometer	27
BR Timer Box programmer	28
12A 2P service switch	29
PDI/PDT Roof base	30
PA Adaptive plate for PDI/T base	30
PMP-A Flat adaptive frame	30
TLE Flexible acoustic silencers	31
TLS Rigid acoustic silencers	33
CAR Backflow damper	34
KFO Duct filter	35
LE Flexible connectors	37

All rights reserved.

This material is for informational purposes only and does not constitute a commercial offer. Brookvent Polska sp. z o.o. accepts no responsibility for errors in this publication and reserves the right to make changes.

# BMV PRO EC roof fans with horizontal air discharge



BMV PRO 1.3 EC fans

BMV PRO 1.9 EC fans

BMV PRO 2.2 EC fans

BMV PRO 2.5 EC fans



PERFORMANCE CURVES

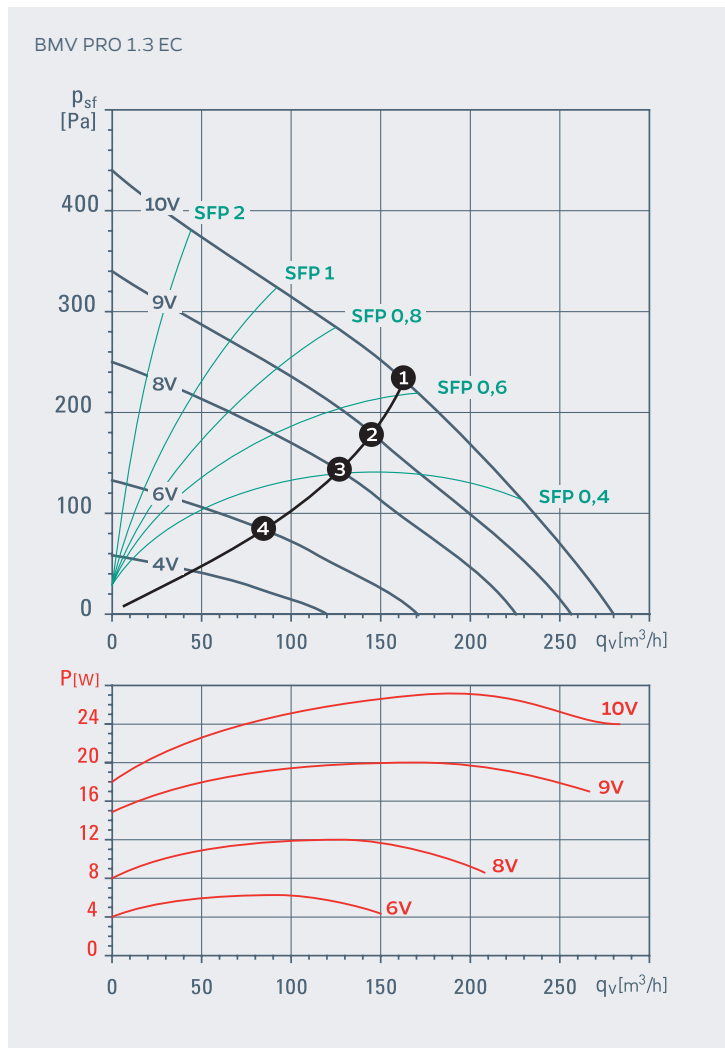

WORK CHARACTERISTICS

Model	Curve characteristics	[rpm]	[W]	[A]	[m <sup>3</sup> /h]*	Values from the graph
BMV PRO 1.3 EC	10 V	3722	27	0,27	160	1
	9 V	3361	20	0,20	145	2
	8 V	2969	14	0,14	130	3
	6 V	2253	7	0,07	95	4

Standards: \* ISO 5801/ DIN 24163; \*\* ISO 3745; \*\* ISO 3744; \*\* ISO 13347

OPTIONAL ACCESSORIES



Electrical accessories



Roof bases



Acoustic silencers



Backflow damper

# BMV PRO 1.9 fans with EC motor



## DESCRIPTION

Roof ventilator designed for external installation, at the ends of ventilation ducting in residential, commercial and industrial buildings with a low level of particulate air pollution. The fan can be operated with a CSR-B controller, which will ensure stable ventilation operation under all conditions and exactly according to the design guidelines.

## FEATURES

- Horizontal air discharge.
- Fan structure made from high-quality plastic.
- Canopy for protection against precipitation.
- Mounting plate fitted with a spigot.
- EC motor equipped with electrical connection box.
- Automatic control is possible if used with a multifunctional control unit, e.g. CSR-B. This will allow for a constant pressure system with selectable operating characteristics.

## TECHNICAL DATA

Phase, rated power [V]	1- 230V
Power supply range [V]	200- 240
Frequency [Hz]	50-60Hz
Max power consumption [W]	90
Max current consumption [A]	0,76
Operating temperature range [oC]	-25°C<T<+60°C*
Weight [kg]	3,5
Protection class IP/ insulation class	IP 54 cl. B

\* under special conditions it is permissible to start the device at a temperature of -30°C

## ELECTRICAL WIRING DIAGRAM

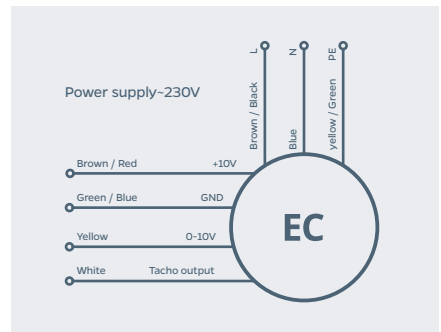

## DIMENSIONS

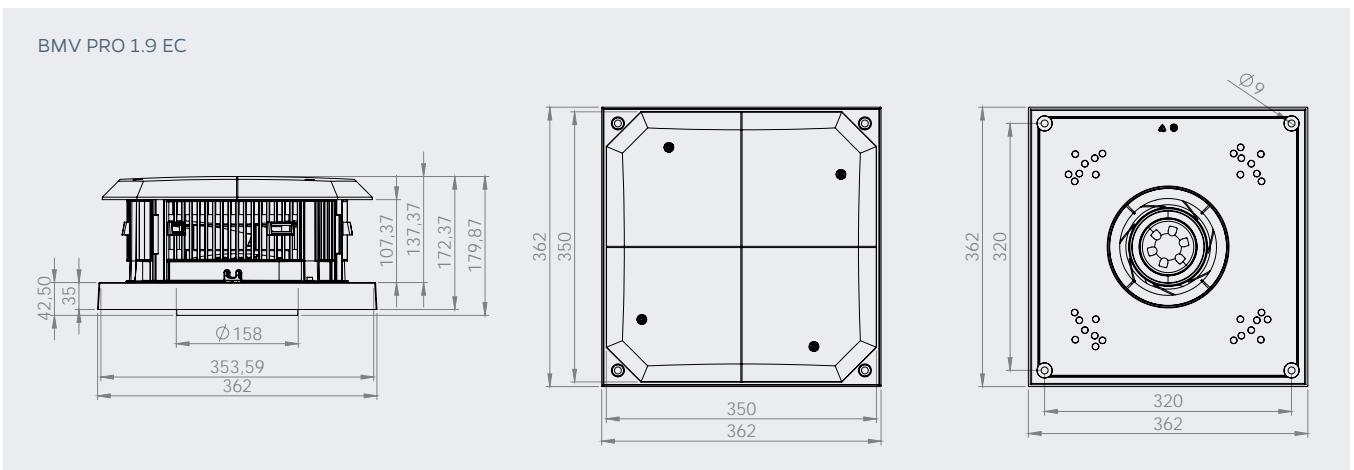

## ACOUSTIC CHARACTERISTICS

Work points	BMV PRO 1.9 EC			Characteristic acoustic (A) [Hz]									Pressure level Lpa depending on distance		
	m³/h	Pa	W	63	125	250	500	1000	2000	4000	8000	Lwa	1m	3m	6m
I	150	70	9	28	34	37	41	42	43	34	28	48	43	34	28
II	200	70	11	24	31	37	41	42	45	37	30	49	44	35	29
III	250	70	14	22	30	37	42	43	47	42	32	51	46	37	31
IV	300	70	17	24	32	40	44	45	48	47	36	53	48	39	33
V	350	70	20	26	32	44	46	48	49	51	41	55	50	41	35
VI	400	70	25	26	34	45	48	50	51	54	46	58	53	44	38
VII	450	70	31	27	36	48	49	53	54	56	50	60	55	46	40

Recommended use of TLE-25-160-1200 flexible silencer, PDT damping/insulating roof base PDI. Further acoustic characteristics of the fan in other operating points are available on request.

PERFORMANCE CURVES

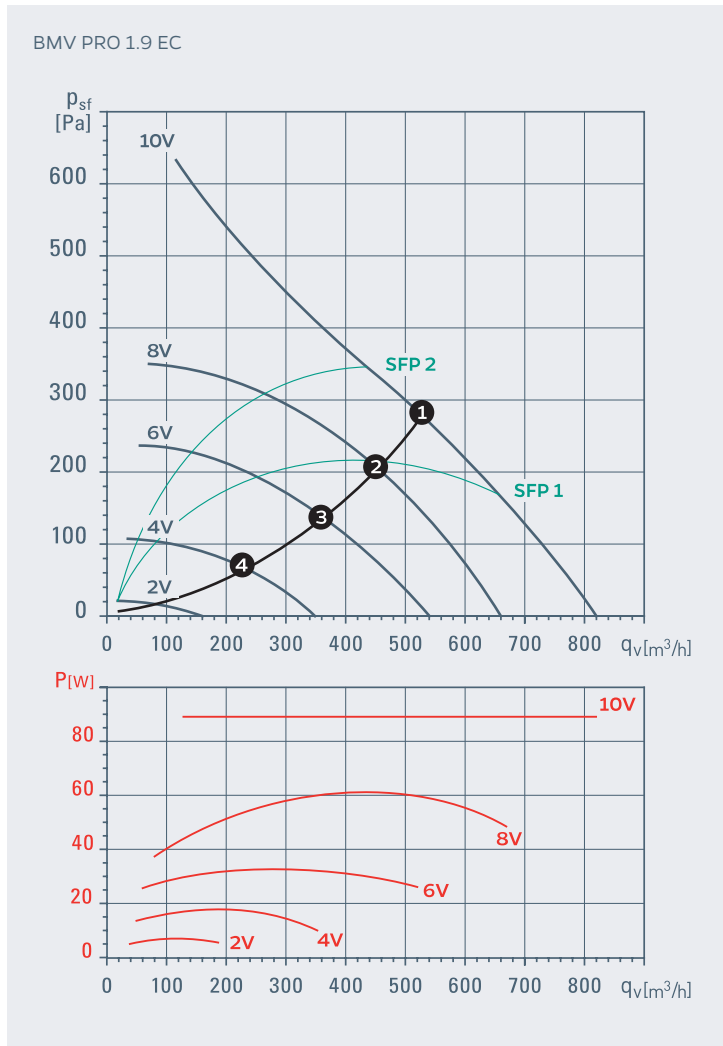

WORK CHARACTERISTICS

Model	Curve characteristics	[rpm]	[W]	[A]	[m³/h]*	Values from the graph
BMV PRO 1.9 EC	10 V	3150	90	0.76	479	1
	8 V	2760	60	0.54	419	2
	6 V	2280	36	0.34	346	3
	4 V	1520	13	0.14	228	4

Standards: \* ISO 5801/ DIN 24163; \*\* ISO 3745; \*\* ISO 3744; \*\* ISO 13347

OPTIONAL ACCESSORIES



Electrical accessories



Roof bases



Acoustic silencers



Backflow damper

# BMV PRO 2.2 fans with EC motor

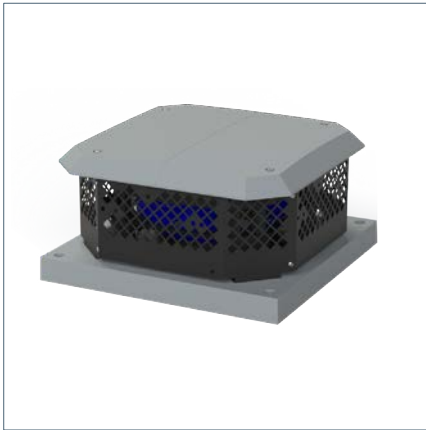

## DESCRIPTION

Roof ventilator designed for external installation, at the ends of ventilation ducting in residential, commercial and industrial buildings with a low level of particulate air pollution. The fan can be operated with a CSR-B controller, which will ensure stable ventilation operation under all conditions and exactly according to the design guidelines.

## FEATURES

- Horizontal air discharge.
- Fan structure made from high-quality plastic.
- Canopy for protection against precipitation.
- Mounting plate fitted with a spigot.
- EC motor equipped with electrical connection box.
- Automatic control is possible if used with a multifunctional control unit, e.g CSR-B. This will allow for a constant pressure system with selectable operating characteristics.

## TECHNICAL DATA

Phase, rated power [V]	1- 230V
Power supply range [V]	200- 240
Frequency [Hz]	50-60Hz
Max power consumption [W]	90
Max current consumption [A]	0,8
Operating temperature range [oC]	-25°C<T<+60°C *
Weight [kg]	4,16
Protection class IP/ insulation class	IP 54 cl. B

\* under special conditions it is permissible to start the device at a temperature of -30°C

## ELECTRICAL WIRING DIAGRAM

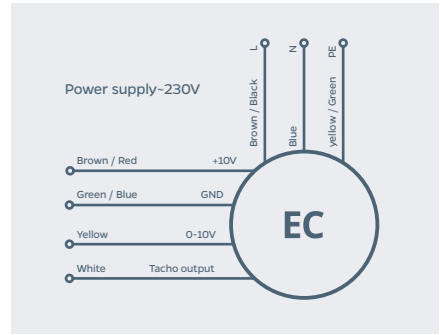

## DIMENSIONS

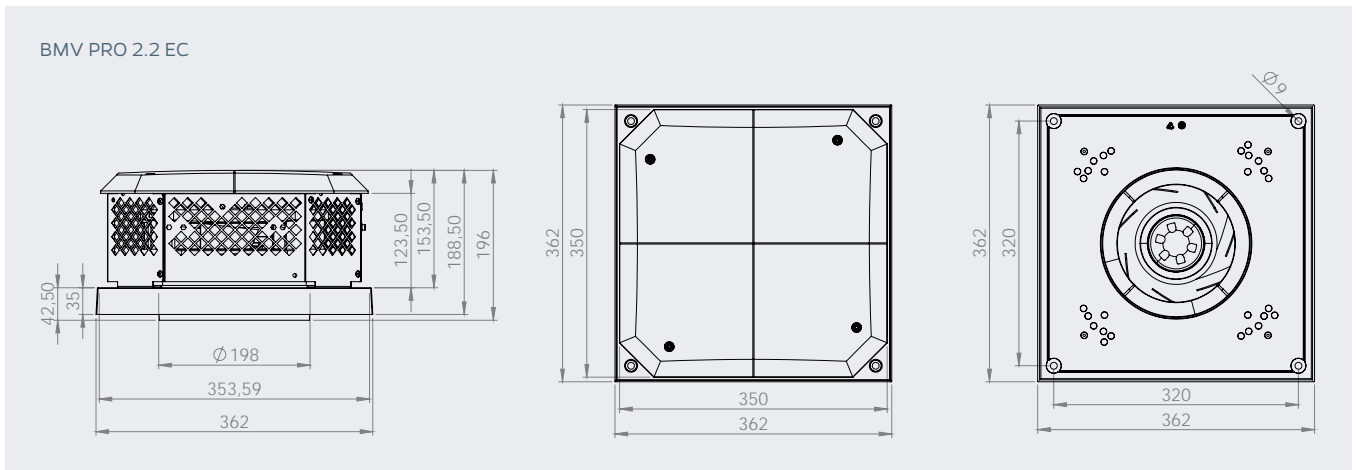

## ACOUSTIC CHARACTERISTICS

Work points	BMV PRO 2.2 EC			Characteristic acoustic (A) [Hz]								Pressure level Lpa depending on distance			
	m³/h	Pa	W	63	125	250	500	1000	2000	4000	8000	Lwa	1m	3m	6m
I	400	70	20	24	36	41	44	46	47	45	32	52	47	38	32
II	450	70	23	24	37	42	45	47	48	49	35	54	49	40	34
III	500	70	26	25	38	43	46	49	50	52	39	56	51	42	36
IV	550	70	30	26	39	45	47	50	51	55	44	58	53	44	38
V	600	70	34	26	40	46	49	51	52	56	48	59	54	45	39
VI	650	70	39	27	40	48	51	53	53	55	52	60	55	46	40
VII	700	70	45	28	41	50	52	54	55	55	55	62	57	48	42

Recommended use of TLE-25-200-1200 flexible silencer, PDT damping/insulating roof base PDI.

Further acoustic characteristics of the fan in other operating points are available on request.

PERFORMANCE CURVES

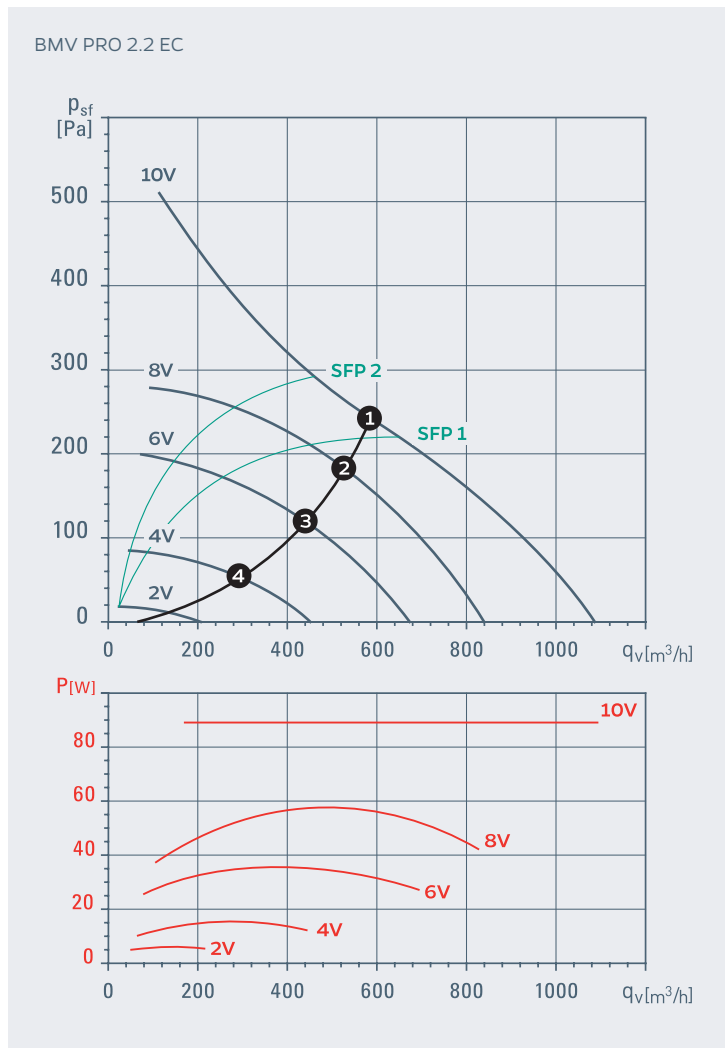

WORK CHARACTERISTICS

Model	Curve characteristics	[rpm]	[W]	[A]	[m <sup>3</sup> /h]*	Values from the graph
BMV PRO 2.2 EC	10 V	2570	90	0.8	594	1
	8 V	2232	60	0.58	521	2
	6 V	1860	36	0.39	431	3
	4 V	1240	13	0.14	284	4

Standards: \* ISO 5801/ DIN 24163; \*\* ISO 3745; \*\* ISO 3744; \*\* ISO 13347

OPTIONAL ACCESSORIES



Electrical accessories



Roof bases



Acoustic silencers



Backflow damper

# BMV PRO 2.5 fans with EC motor



## DESCRIPTION

Roof ventilator designed for external installation, at the ends of ventilation ducting in residential, commercial and industrial buildings with a low level of particulate air pollution. The fan can be operated with a CSR-B controller, which will ensure stable ventilation operation under all conditions and exactly according to the design guidelines.

## FEATURES

- Horizontal air discharge.
- Fan structure made from high-quality plastic.
- Canopy for protection against precipitation.
- Mounting plate fitted with a spigot.
- EC motor equipped with electrical connection box.
- Automatic control is possible if used with a multifunctional control unit, e.g CSR-B. This will allow for a constant pressure system with selectable operating characteristics.

## TECHNICAL DATA

Phase, rated power [V]	1- 230V
Power supply range [V]	200- 240
Frequency [Hz]	50-60Hz
Max power consumption [W]	170
Max current consumption [A]	1,5
Operating temperature range [oC]	-25°C<T<+60°C *
Weight [kg]	5.0
Protection class IP/ insulation class	IP 54 cl. B

\* under special conditions it is permissible to start the device at a temperature of -30°C

## ELECTRICAL WIRING DIAGRAM

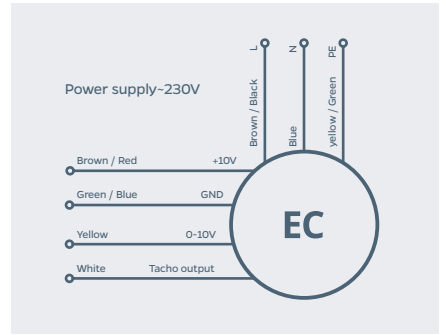

## DIMENSIONS

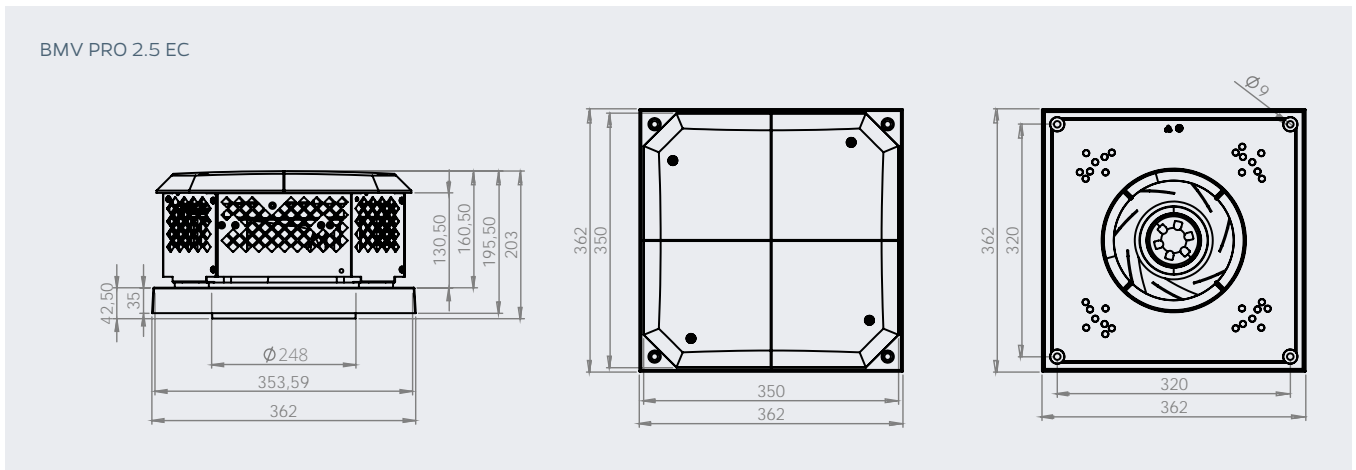

## ACOUSTIC CHARACTERISTICS

Work points	BMV PRO 2.5 EC			Characteristic acoustic (A) [Hz]									Pressure level Lpa depending on distance		
	m³/h	Pa	W	63	125	250	500	1000	2000	4000	8000	Lwa	1m	3m	6m
I	700	70	34	29	39	44	48	51	53	53	42	58	53	44	38
II	750	70	38	31	40	45	49	52	54	55	44	59	54	45	39
III	800	70	42	32	41	46	50	53	54	57	46	61	56	47	41
IV	850	70	46	33	41	47	51	54	55	58	48	62	57	48	42
V	900	70	52	34	43	48	52	55	55	59	50	63	58	49	43
VI	1000	70	62	37	45	50	54	57	57	62	53	65	60	51	45
VII	1100	70	74	36	45	52	56	59	58	63	56	67	62	53	47

Recommended use of TLE-25-250-1200 flexible silencer, PDT damping/insulating roof base PDI. Further acoustic characteristics of the fan in other operating points are available on request.

PERFORMANCE CURVES

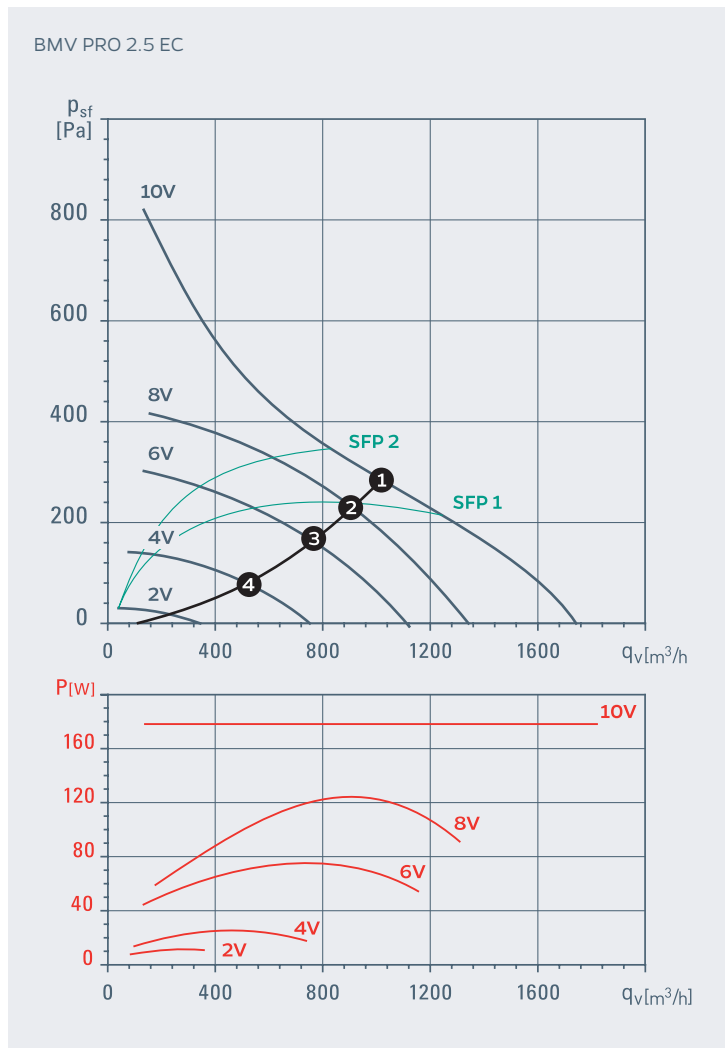

WORK CHARACTERISTICS

Model	Curve characteristics	[rpm]	[W]	[A]	[m³/h]*	Values from the graph
BMV PRO 2.5 EC	10 V	2480	170	1.5	997	1
	8 V	2230	120	1.1	892	2
	6 V	1930	80	0.76	776	3
	4 V	1290	26	0.28	517	4

Standards: \* ISO 5801/ DIN 24163; \*\* ISO 3745; \*\* ISO 3744; \*\* ISO 13347

OPTIONAL ACCESSORIES

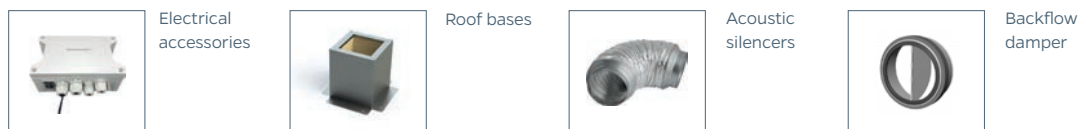





**BMV PRO EC** roof fans with **vertical** air discharge

[BMV PRO 1.3 EC Vertical fans](#)

[BMV PRO 1.9 EC Vertical fans](#)

[BMV PRO 2.2 EC Vertical fans](#)

[BMV PRO 2.5 EC Vertical fans](#)

# BMV PRO 1.3 Vertical fans with EC motor



## DESCRIPTION

A roof fan designed for outdoor installation at the ends of ventilation ducting in residential, commercial and industrial buildings, where the degree of air pollution with solid particles is low. The fan can work with the CSR-B controller, which will ensure stable ventilation in all conditions and exactly according to the design guidelines.

## FEATURES

- Vertical air discharge.
- Structure made of galvanised sheet metal.
- Mounting plate fitted with spigot.
- EC motor fitted with a box for electrical connection.
- Automatic control is possible if used with a multifunctional control unit, e.g CSR-B. This will allow for a constant pressure system with selectable operating characteristics.

## TECHNICAL DATA

Phase, rated power [V]	1- 230V
Power supply range [V]	200- 240
Frequency [Hz]	50-60Hz
Max power consumption [W]	27
Max current consumption [A]	0,27
Operating temperature range [oC]	-25°C<T<+55°C
Weight [kg]	5
Protection class IP/ insulation class	IP 54 cl. B

## ELECTRICAL WIRING DIAGRAM

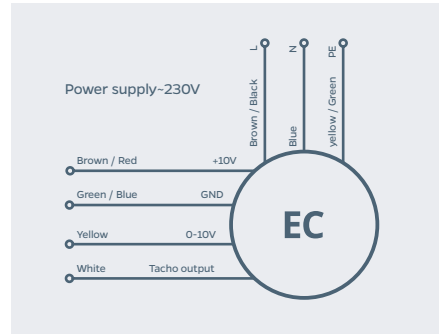

## DIMENSIONS

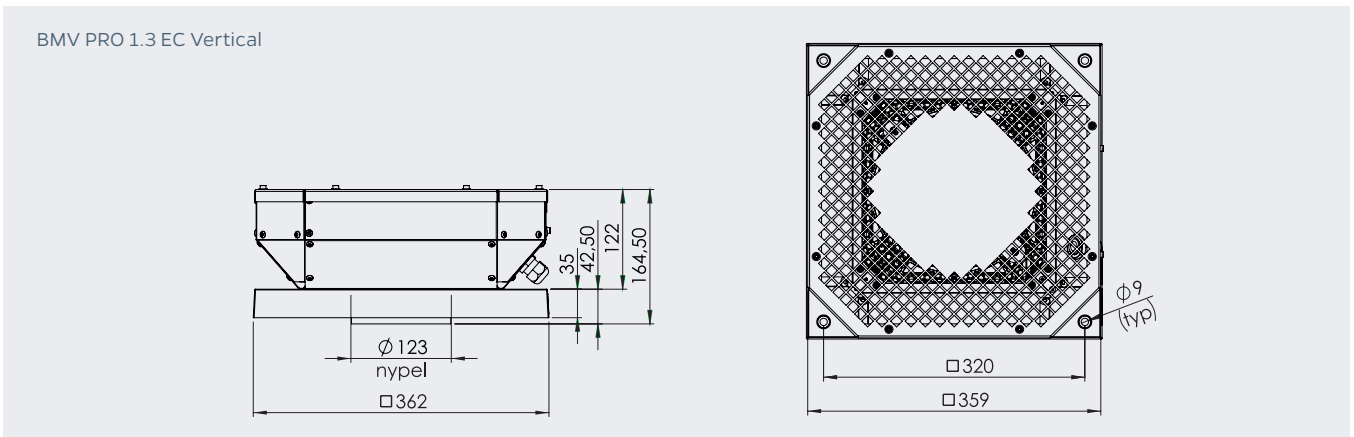

## ACOUSTIC CHARACTERISTICS

Work points	BMV PRO 1.3 EC VERTICAL			Characteristic acoustic (A) [Hz]								Pressure level Lpa depending on distance			
	m³/h	Pa	W	63	125	250	500	1000	2000	4000	8000	Lwa	1m	3m	6m
I	50	70	4	16	28	39	39	39	39	33	23	46	41	31	25
II	100	70	6	17	29	35	40	41	43	38	28	47	42	33	27
III	150	70	9	21	33	40	45	47	49	46	37	53	48	39	33
IV	200	70	16	25	37	47	51	53	54	53	46	60	55	45	39

Recommended use of TLE-25-125-1200 flexible silencer, PDT damping/insulating roof base PDI. Further acoustic characteristics of the fan in other operating points are available on request.

PERFORMANCE CURVES

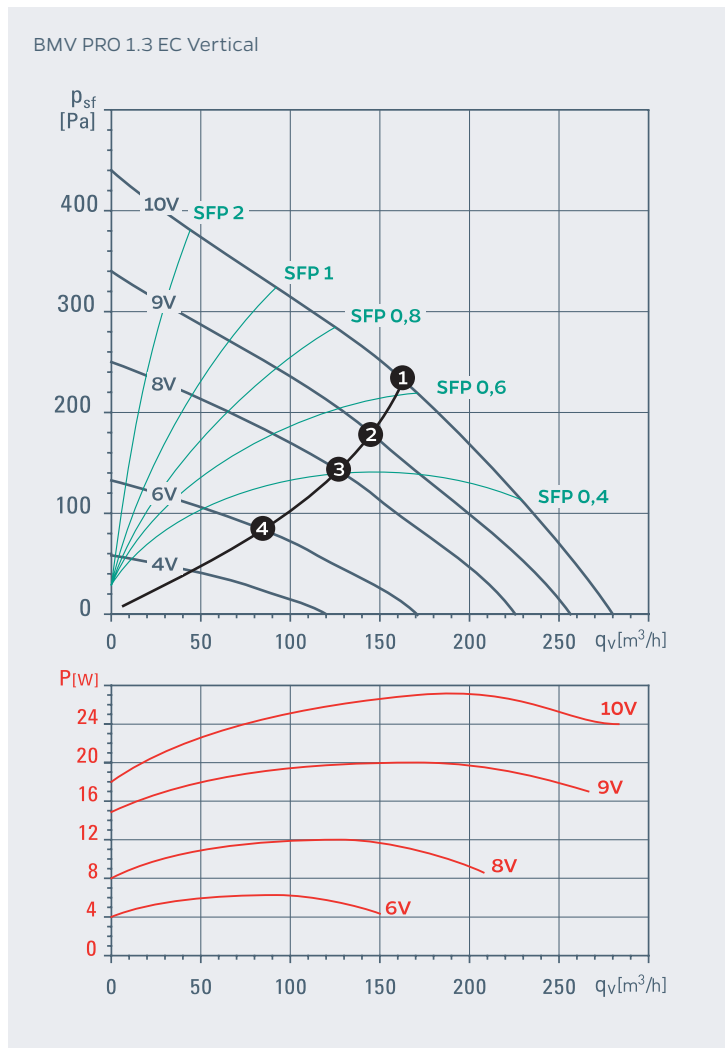

WORK CHARACTERISTICS

Model	Curve characteristics	[rpm]	[W]	[A]	[m <sup>3</sup> /h]*	Values from the graph
BMV PRO 1.3 EC	10 V	3722	27	0,27	160	1
	9 V	3361	20	0,20	145	2
	8 V	2969	14	0,14	130	3
	6 V	2253	7	0,07	95	4

Standards: \* ISO 5801/ DIN 24163; \*\* ISO 3745; \*\* ISO 3744; \*\* ISO 13347

OPTIONAL ACCESSORIES



Electrical accessories



Roof bases



Acoustic silencers



Backflow damper

# BMV PRO 1.9 Vertical fans with EC motor



## DESCRIPTION

A roof fan designed for outdoor installation at the ends of ventilation ducting in residential, commercial and industrial buildings, where the degree of air pollution with solid particles is low. The fan can work with the CSR-B controller, which will ensure stable ventilation in all conditions and exactly according to the design guidelines.

## FEATURES

- Vertical air discharge.
- Structure made of galvanised sheet metal.
- Mounting plate fitted with spigot.
- EC motor fitted with a box for electrical connection.
- Automatic control is possible if used with a multifunctional control unit, e.g CSR-B. This will allow for a constant pressure system with selectable operating characteristics.

## TECHNICAL DATA

Phase, rated power [V]	1-230V
Power supply range [V]	200- 240
Frequency [Hz]	50-60Hz
Max power consumption [W]	90
Max current consumption [A]	0,76
Operating temperature range [oC]	-25°C<T<+55°C
Weight [kg]	5
Protection class IP/ insulation class	IP 54 cl. B

## ELECTRICAL WIRING DIAGRAM

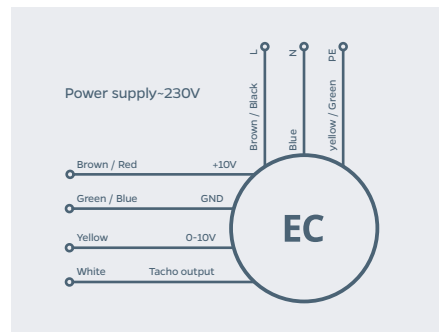

## DIMENSIONS

BMV PRO 1.9 EC Vertical

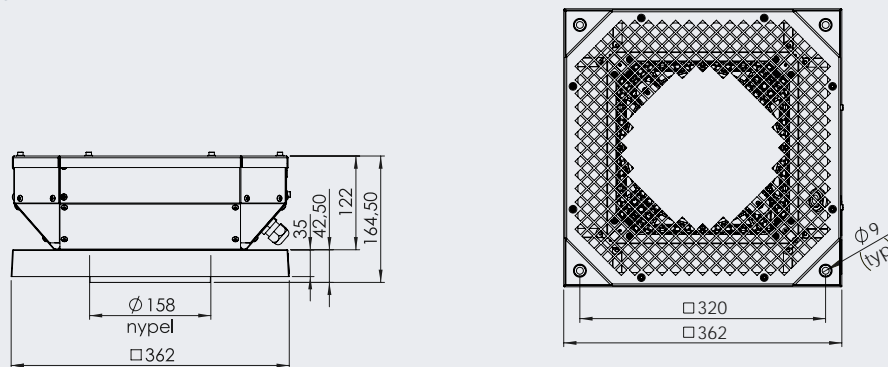

## ACOUSTIC CHARACTERISTICS

Work points	BMV PRO 1.9 EC VERTICAL			Characteristic acoustic (A) [Hz]								Pressure level Lpa depending on distance			
	m <sup>3</sup> /h	Pa	W	63	125	250	500	1000	2000	4000	8000	Lwa	1m	3m	6m
I	150	70	9	28	34	37	41	42	43	34	28	48	43	34	28
II	200	70	11	24	31	37	41	42	45	37	30	49	44	35	29
III	250	70	14	22	30	37	42	43	47	42	32	51	46	37	31
IV	300	70	17	24	32	40	44	45	48	47	36	53	48	39	33
V	350	70	20	26	32	44	46	48	49	51	41	55	50	41	35
VI	400	70	25	26	34	45	48	50	51	54	46	58	53	44	38
VII	450	70	31	27	36	48	49	53	54	56	50	60	55	46	40

Recommended use of TLE-25-160-1200 flexible silencer, PDT damping/insulating roof base PDI. Further acoustic characteristics of the fan in other operating points are available on request.

PERFORMANCE CURVES

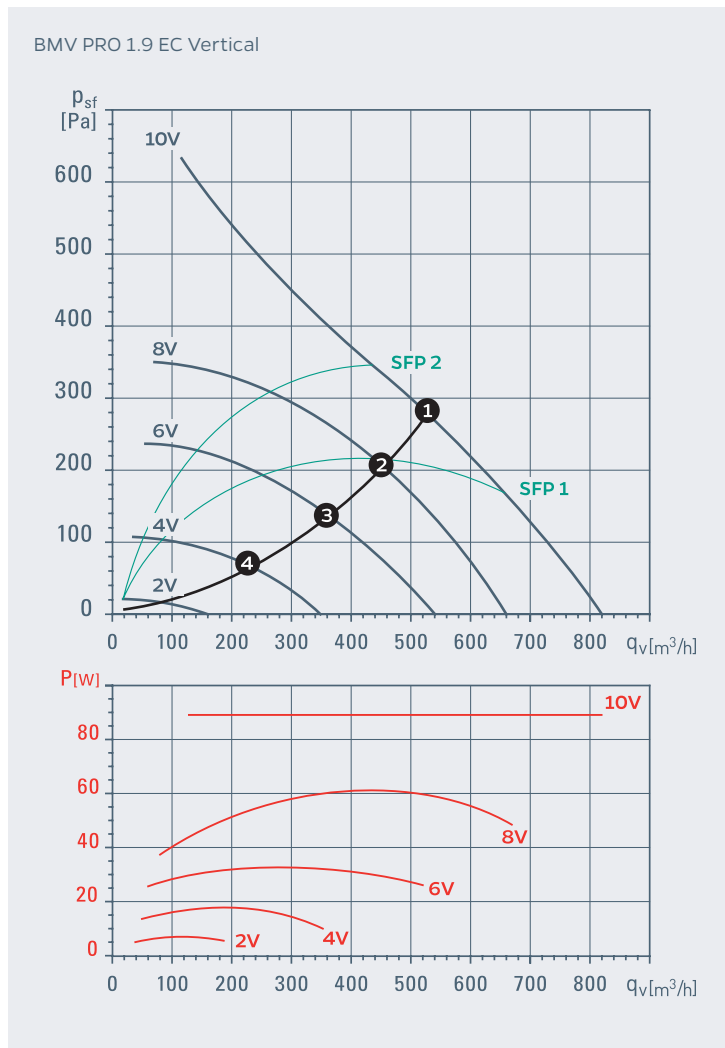

WORK CHARACTERISTICS

Model	Curve characteristics	[rpm]	[W]	[A]	[m³/h]*	Values from the graph
BMV PRO 1.9 EC Vertical	10 V	3150	90	0.76	479	1
	8 V	2760	60	0.54	419	2
	6 V	2280	36	0.34	346	3
	4 V	1520	12	0.14	228	4

Standards: \* ISO 5801/ DIN 24163; \*\* ISO 3745; \*\* ISO 3744; \*\* ISO 13347

OPTIONAL ACCESSORIES



Electrical accessories



Roof bases



Acoustic silencers



Backflow damper

# BMV PRO 2.2 Vertical fans with EC motor



### DESCRIPTION

A roof fan designed for outdoor installation at the ends of ventilation ducting in residential, commercial and industrial buildings, where the degree of air pollution with solid particles is low. The fan can work with the CSR-B controller, which will ensure stable ventilation in all conditions and exactly according to the design guidelines.

### FEATURES

- Vertical air discharge.
- Structure made of galvanised sheet metal.
- Mounting plate fitted with spigot.
- EC motor fitted with a box for electrical connection.
- Automatic control is possible if used with a multifunctional control unit, e.g CSR-B. This will allow for a constant pressure system with selectable operating characteristics.

### TECHNICAL DATA

Phase, rated power [V]	1-230V
Power supply range [V]	200- 240
Frequency [Hz]	50-60Hz
Max power consumption [W]	90
Max current consumption [A]	0,8
Operating temperature range [oC]	-25°C<T<+55°C
Weight [kg]	6
Protection class IP/ insulation class	IP 54 cl. B

### ELECTRICAL WIRING DIAGRAM

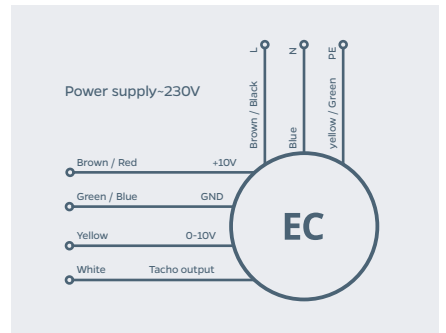

### DIMENSIONS

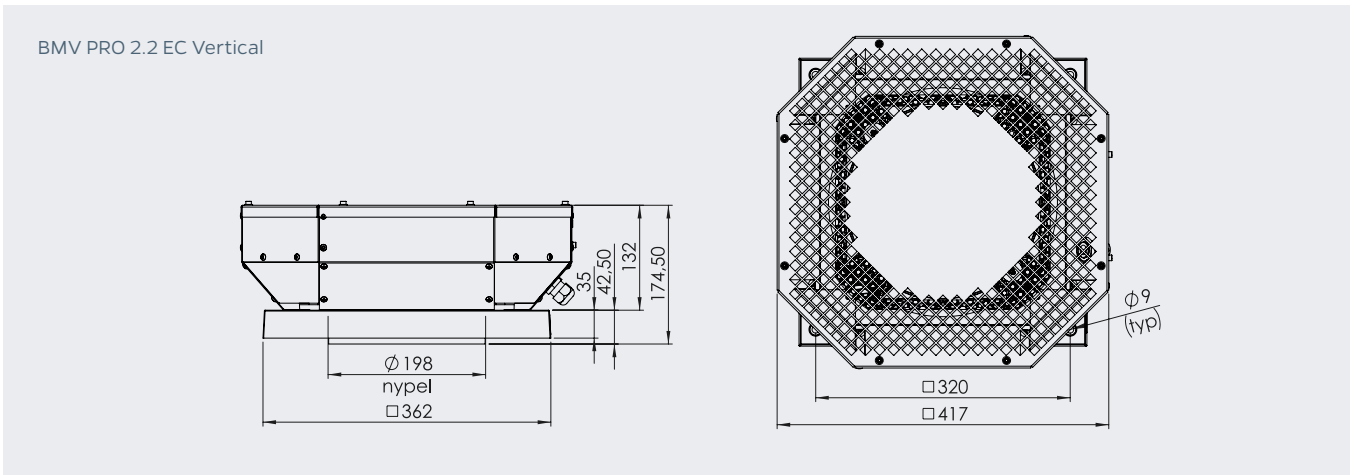

### ACOUSTIC CHARACTERISTICS

Work points	BMV PRO 2.2 EC VERTICAL			Characteristic acoustic (A) [Hz]									Pressure level Lpa depending on distance		
	m³/h	Pa	W	63	125	250	500	1000	2000	4000	8000	Lwa	1m	3m	6m
I	400	70	20	24	36	41	44	46	47	45	32	52	47	38	32
II	450	70	23	24	37	42	45	47	48	49	35	54	49	40	34
III	500	70	26	25	38	43	46	49	50	52	39	56	51	42	36
IV	550	70	30	26	39	45	47	50	51	55	44	58	53	44	38
V	600	70	34	26	40	46	49	51	52	56	48	59	54	45	39
VI	650	70	39	27	40	48	51	53	53	55	52	60	55	46	40
VII	700	70	45	28	41	50	52	54	55	55	55	62	57	48	42

Recommended use of TLE-25-200-1200 flexible silencer, PDT damping/insulating roof base PDI. Further acoustic characteristics of the fan in other operating points are available on request.

PERFORMANCE CURVES

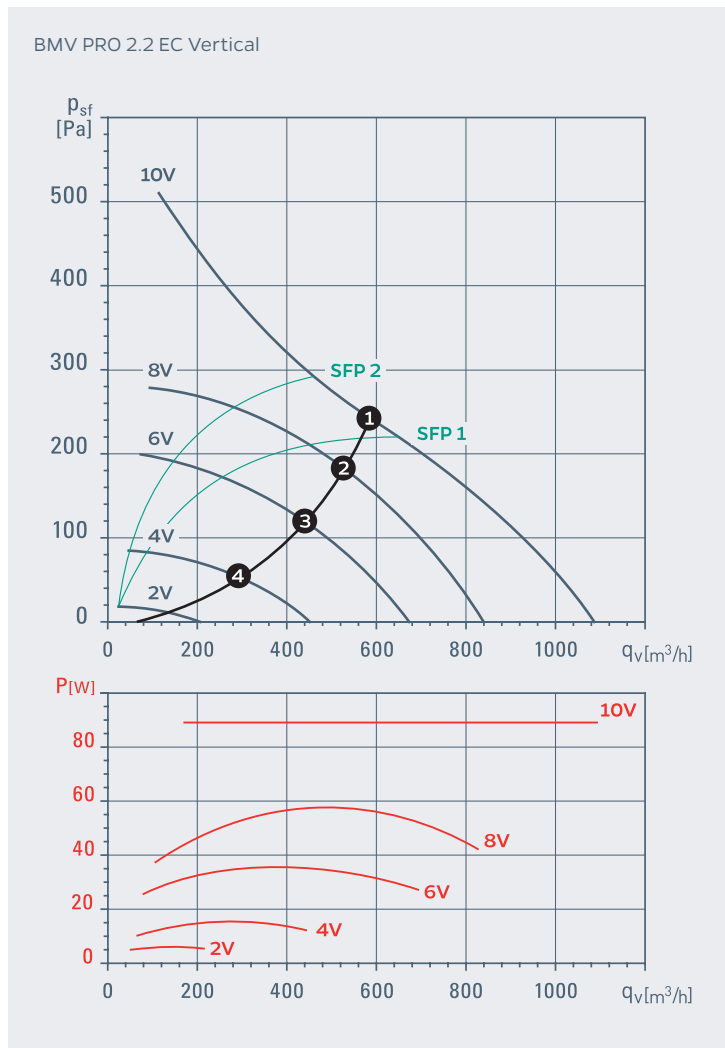



WORK CHARACTERISTICS

Model	Curve characteristics	[rpm]	[W]	[A]	[m³/h]*	Values from the graph
BMV PRO 2.2 EC Vertical	10 V	2570	90	0.8	594	1
	8 V	2232	60	0.58	521	2
	6 V	1860	36	0.39	431	3
	4 V	1240	12	0.14	284	4

Standards: \* ISO 5801/ DIN 24163; \*\* ISO 3745; \*\* ISO 3744; \*\* ISO 13347

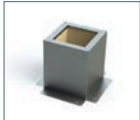
OPTIONAL ACCESSORIES

	<p>Electrical accessories</p>		<p>Roof bases</p>		<p>Acoustic silencers</p>		<p>Backflow damper</p>
---	-------------------------------	---	-------------------	---	---------------------------	--	------------------------

# BMV PRO 2.5 Vertical fans with EC motor



### DESCRIPTION

A roof fan designed for outdoor installation at the ends of ventilation ducting in residential, commercial and industrial buildings, where the degree of air pollution with solid particles is low. The fan can work with the CSR-B controller, which will ensure stable ventilation in all conditions and exactly according to the design guidelines.

### FEATURES

- Vertical air discharge.
- Structure made of galvanised sheet metal.
- Mounting plate fitted with spigot.
- EC motor fitted with a box for electrical connection.
- Automatic control is possible if used with a multifunctional control unit, e.g CSR-B. This will allow for a constant pressure system with selectable operating characteristics.

### TECHNICAL DATA

Phase, rated power [V]	1-230V
Power supply range [V]	200- 240
Frequency [Hz]	50-60Hz
Max power consumption [W]	170
Max current consumption [A]	1,5
Operating temperature range [oC]	-25°C<T<+55°C
Weight [kg]	7
Protection class IP/ insulation class	IP 54 cl. B

### ELECTRICAL WIRING DIAGRAM

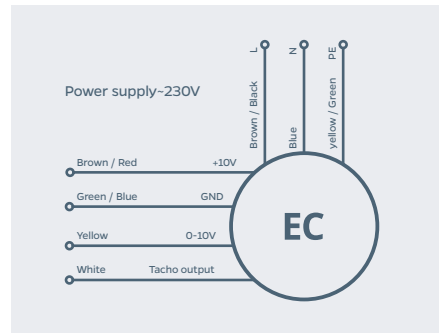

### DIMENSIONS

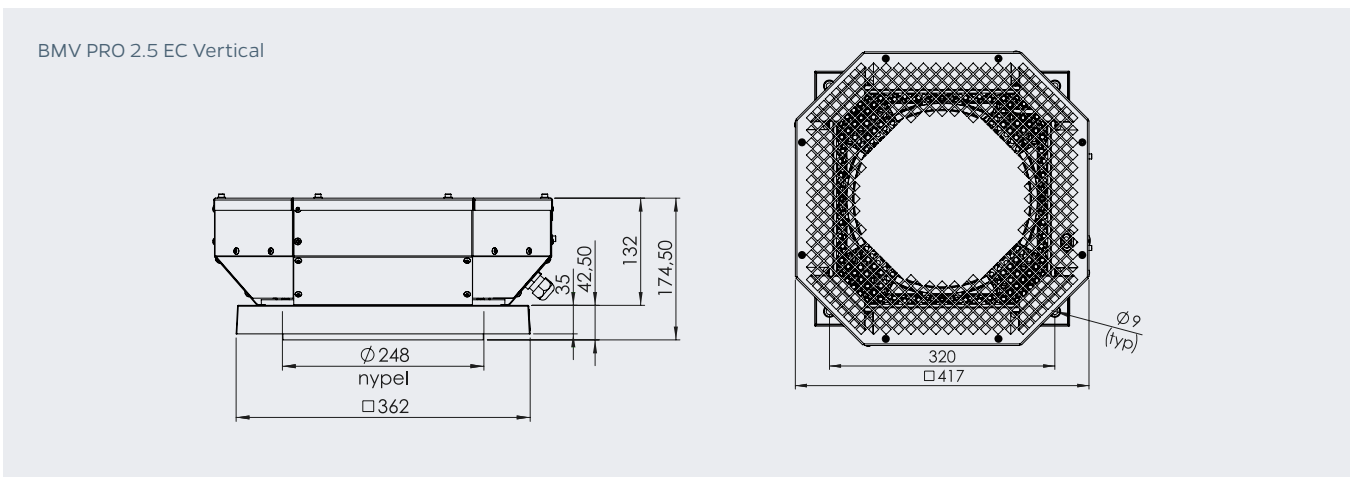

### ACOUSTIC CHARACTERISTICS

Work points	BMV PRO 2.5 EC VERTICAL			Characteristic acoustic (A) [Hz]								Pressure level Lpa depending on distance			
	m³/h	Pa	W	63	125	250	500	1000	2000	4000	8000	Lwa	1m	3m	6m
I	700	70	34	29	39	44	48	51	53	53	42	58	53	44	38
II	750	70	38	31	40	45	49	52	54	55	44	59	54	45	39
III	800	70	42	32	41	46	50	53	54	57	46	61	56	47	41
IV	850	70	46	33	41	47	51	54	55	58	48	62	57	48	42
V	900	70	52	34	43	48	52	55	55	59	50	63	58	49	43
VI	1000	70	62	37	45	50	54	57	57	62	53	65	60	51	45
VII	1100	70	74	36	45	52	56	59	58	63	56	67	62	53	47

Recommended use of TLE-25-250-1200 flexible silencer, PDT damping/insulating roof base PDI. Further acoustic characteristics of the fan in other operating points are available on request.

PERFORMANCE CURVES

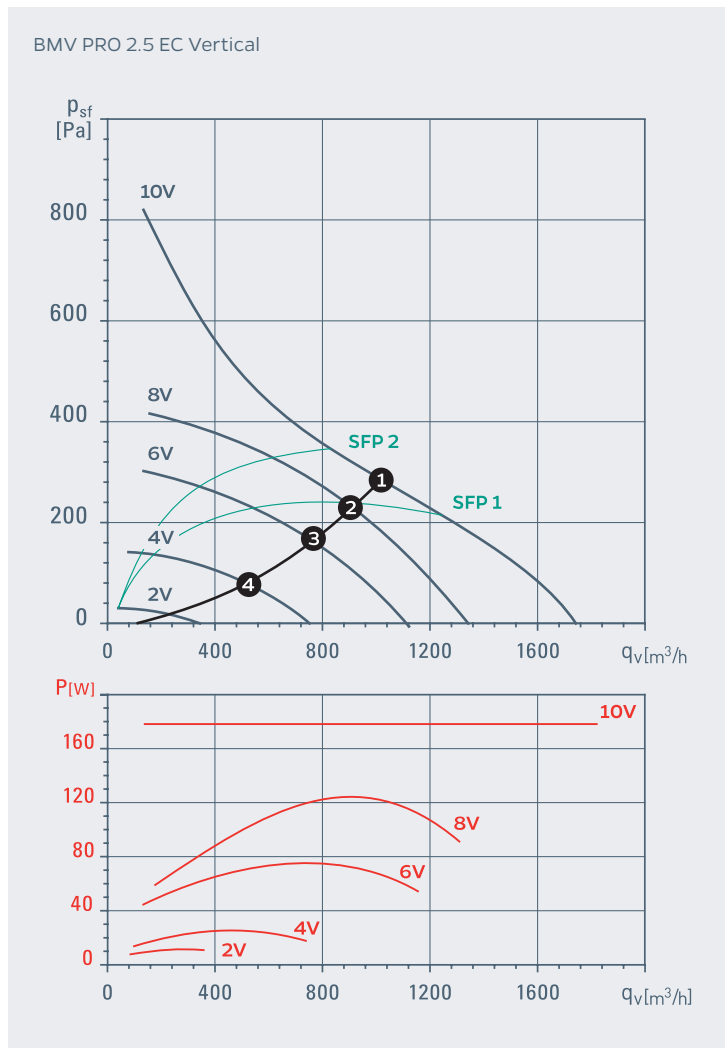

WORK CHARACTERISTICS

Model	Curve characteristics	[rpm]	[W]	[A]	[m³/h]*	Values from the graph
BMV PRO 2.5 EC Vertical	10 V	2480	170	1.5	997	1
	8 V	2230	120	1.1	892	2
	6 V	1930	80	0.76	776	3
	4 V	1290	26	0.28	517	4

Standards: \* ISO 5801/ DIN 24163; \*\* ISO 3745; \*\* ISO 3744; \*\* ISO 13347

ACCESSORIES



Electrical accessories



Roof bases



Acoustic silencers



Backflow damper



# Accessories

## **Electrical accessories:**

CSR-B EC W controller, CSR-B EC Zero Plus W controller, CSR-B

EC NFC W controller

BR-S 1/010 potentiometer

BR-2/010 potentiometer

BR-TWIN 1-010 EC potentiometer

BR Timer Box programmer

12A 2P service switch

PDI/PDT Roof base

PA Adaptive plate for PDI/T base

PMP-A Flat adaptive frame

TLE Flexible acoustic silencers

TLS Rigid acoustic silencers

CAR Backflow damper

KFO Duct filter

LE Flexible connectors

INSTALLATION EXAMPLES

1. CSR-B
2. roof base
3. base plate with a connector
4. backflow damper
5. LE flexible coupler
6. TLE flexible silencer or TLS rigid silencer
7. ventilation ducting

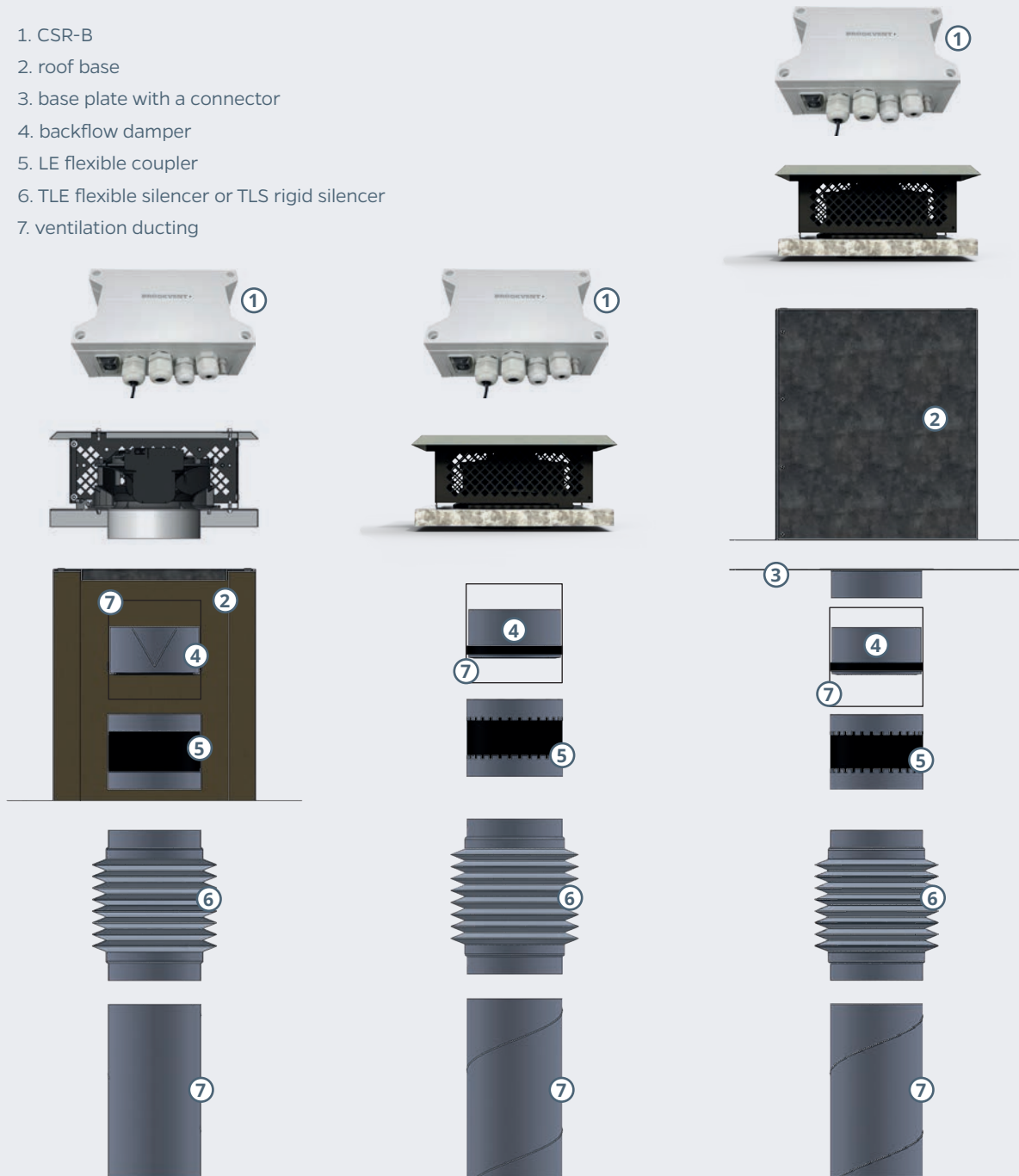

## ELECTRICAL ACCESSORIES

### CSR-B EC W, CSR-B EC Zero Plus W, CSR-B EC NFC W controller



\* Photo shows CSR-B EC W

#### DESCRIPTION OF OPERATION

Controllers of the CSR-B series are constant pressure regulators designed for cooperation with duct and roof fans with EC motors. By continuously controlling the fan speed, they ensure constant pressure in the ventilation ducting. Based on a PI controller, CSR-B controllers have the option to set a constant fan power and programmable upper and lower fan control limits.

#### FEATURES

- Operational status indication on the housing
- Safe two-pole switch
- Optional day and night settings
- Convenient assembly and connection
- Fuse to protect the fan against overloads or short circuits
- Quick configuration via phone app (NFC model)



#### TECHNICAL DATA

Parameter	CSR-B EC W	CSR-B EC Zero Plus W	CSR-B EC NFC W
Power supply	230VAC/50Hz	230VAC/50Hz	230VAC/50Hz
Protection	2,5A	2,5A	2,5A
Enclosure dimensions	162x100x68	162x100x68	162x100x68
Housing	PC/ABS plastic with gasket	PC/ABS plastic with gasket	PC/ABS plastic with gasket
Weight	420g	420g	420g
Motor control type	0-10V	0-10V	0-10V
Pressure range	+/- 800 Pa	+/- 800 Pa	+/- 800 Pa
Operating temperature	-25/60°C	-25/60°C	-25/60°C
Degree of protection	IP65	IP65	IP65
Mounting	Wall mounting	Wall mounting	Wall mounting
Digital inputs	Input in closed / open	Input in closed / open	Input in closed / open
Digital outputs (alarms)	Relay output potential-free	None	Relay output potential-free
Controller programming	Control keypad, integrated LCD display	0-10 potentiometer with LEDs and keypad	Application
Enclosure switch	From below	From below	From below

#### FEATURES

Parameter	CSR-B EC W	CSR-B EC Zero Plus W	CSR-B EC NFC W
Infinitely variable speed control fan speed	●	●	●
Night setting	●	triggered by an external clock	●
Built-in clock	●		●
NFC module			●
Power switch on the housing	●	●	●
Fan power supply	●	●	●
Alarm output	●		●
Error information	●	●	●
Overvoltage protection	●	●	●
Fail-safe mode	●	●	●
Operation and error indication outside the housing	●	●	●

## Potentiometer **BR-S 1/010**



### OPERATION

Potentiometer designed for setting the desired rotational speed for fans equipped with electronically commutated EC motors.

The potentiometer requires a power supply of max. 10-12 V DC / 1 mA, which is available from EC fans. The output is a stepless 0-10 V DC signal. Resistance: 10 k $\Omega$ .

### FEATURES

- Device designed to work with fans with EC motors controlled by a 0-10V signal, equipped with a +10V output
- Setting of the desired analogue signal value in the range from 0 to 10V using the main knob
- ABS housing protecting against accidental changes in settings
- Housing protection class IP 65

# Potentiometer **BR-2/010**



## OPERATION

The BR-2/010 potentiometer was developed for controlling devices that need an infinitely variable control signal. The supply voltage range is 0-12 VDC, e.g. EC motors, controlled by a 0-10V signal. The output voltage is infinitely adjustable from 0 to the supply voltage (Us) by means of a knob. It is equipped with a switch (potential-free contact) for remote switching on/off of external devices. The potentiometer is suitable for both recessed (IP44) and surface mounting (IP54).

## MOUNTING AND DIMENSIONS

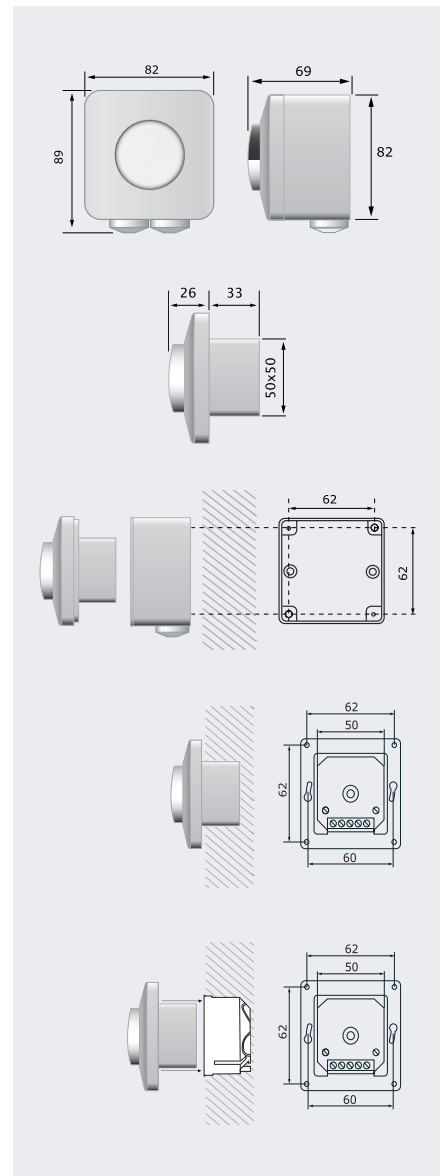

## KEY FEATURES

- Infinitely variable voltage adjustment by means of a knob/potentiometer from 0 to Us
- Switch - voltage-free disconnecter for switching on/off the unit.
- Dust-tight housing.
- Surface-mounted or flush-mounted.

## STANDARDS

- Low Voltage Directive 2014/35/EC.
- Waste Electrical and Electronic Equipment Directive.
- WEEE Directive 2012/19 / EU.
- RoHS Directive 2011/65 / EU on the restriction of the use of harmful substances in electrical and electronic equipment.

## SCOPE OF APPLICATION

- Various applications where a DC control signal is required.
- For indoor use only.

## TECHNICAL DATA

Parameter	Value	
Supply (control) voltage	max. 12 VDC / 1 mA	
Output voltage	0—Us	
Switch scale - switch parameters	4 A (250 VAC)   10 A / 12 VDC	
Degree of protection	IP44 / IP54 (according to EN 60529)	
Ambient conditions	Temperature	0—50 °C
	Humidity	<95 % rH (without condensate)

## CONNECTIONS

Us	Supply voltage (0-12 VDC)
+	Output voltage (0-Us)
-	Grounding
$\text{r} \text{ } \text{O}_1$	Voltage-free contact for remote ON/OFF of external devices
Connections	for cables with a maximum cross-section of 2.5mm

# BR-TWIN 1-010 EC potentiometer



## DESCRIPTION

The BR-TWIN 1-010 EC potentiometer is designed for electronically commutated EC motors. It allows for setting two speeds and has a NO input (e.g. for a timer or CO2 sensor). The potentiometer is supplied with a signal up to  $U_c \text{ max} = 15V$ . It has the IP 65 housing protection class .

## INSTALLATION

The device is very easy and quick to connect and operate. The potentiometer is designed for external installation on vertical surfaces

## ELECTRICAL DIAGRAM

Diagram showing the connection of multiple fans to a single external O/1 signal (maximum 5).

## FEATURES

- The potentiometer offers the option of setting two speeds, V1 and V2
- The speed of EC fans is controlled by a 0-Uc max signal ( $U_c \text{ max} = 15V$ )
- The built-in normally open input allows switching between V1 and V2 using an external O/1 signal
- The O/1 signal used to switch settings can be generated by additional external devices, e.g. CO2 sensors or timers
- The use of an external BR timer box allows the ventilation to operate in day/night mode.
- One external timer can control up to 5 potentiometers. It is recommended to use one timer for potentiometers controlling fans, e.g. within one shaft

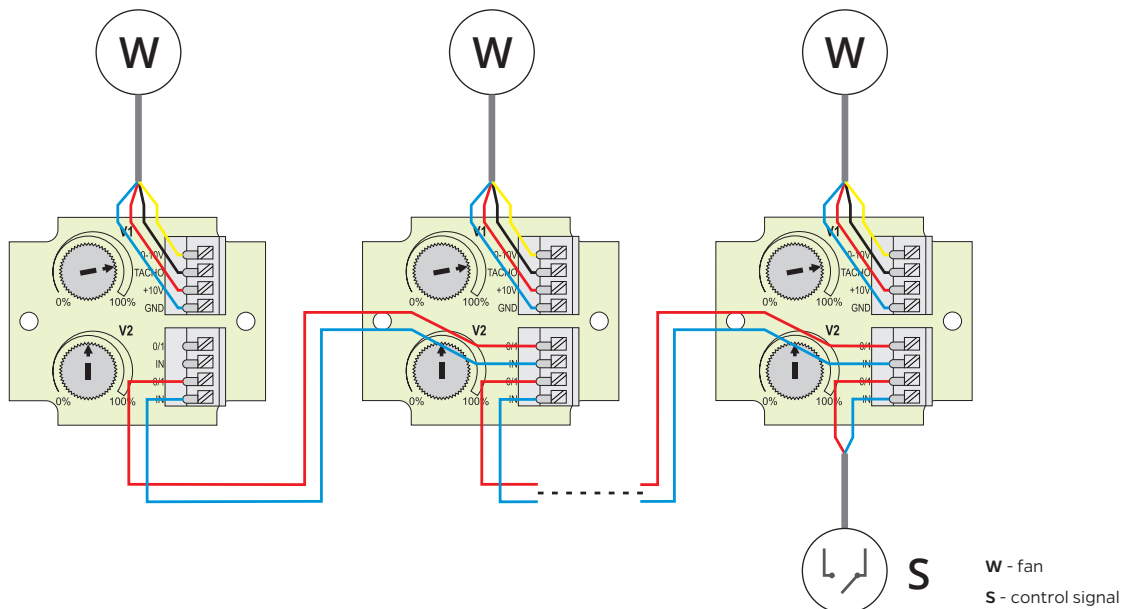

## BR-TWIN 1-010 EC POTENTIOMETER FOR FANS WITH EC MOTORS

Parameter	Wartość
Maximum power supply	max 15V DC/1mA
Housing dimensions	61mm x 61mm x 40mm
Housing	Tworzywo ABS
Weight	100g
Motor control type	typically 0-10V or from 0 to supply voltage
Operating temperature	od -25 do 60°C
Protection rating	IP65
Mounting	wall-mounted
Digital inputs	normally open, switching input
Analogue outputs	analogue output 0-Uc max (e.g. 0-10V)
Control method	potentiometers, switching input

# BR Timer Box programmer



## DESCRIPTION

The BR Timer Box allows you to set a 0/1 signal which, when connected to a potentiometer/ controller, forces a change in the fan's operating mode. The timer allows for automatic signal change within a specific time frame set by the user. This makes it possible to adapt the settings depending on the time of day with minute-by-minute accuracy. The timer is capable of handling more than one potentiometer/controller at a time.

The programmer allows you to set 8 cycles of signal activation and deactivation throughout the day. There is also an option to change the time from summer to winter and vice versa. The current time and operating mode are shown on the display.

## INSTALLATION

The BR Timer Box programmer is supplied in an insulated housing (IP 55) that allows for wall mounting. The programmer is designed for outdoor installation on vertical surfaces.



## DIMENSIONS [mm]

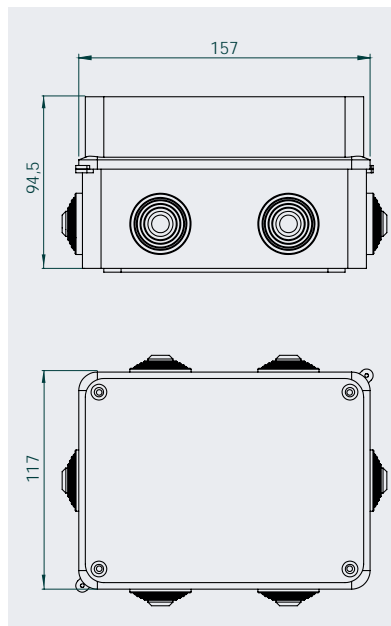

## ELECTRICAL DIAGRAM

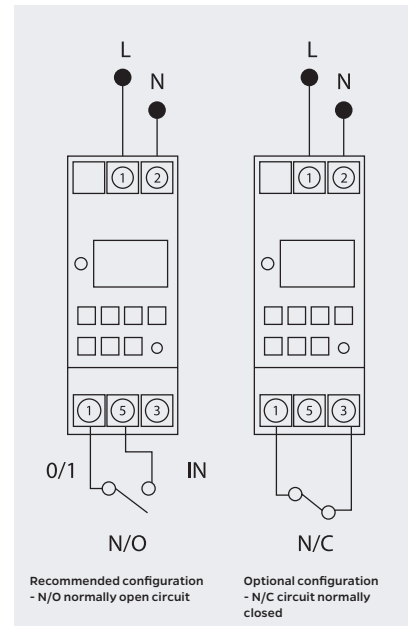

## TECHNICAL DATA

Parameter	Value
Power supply	230V
Maximum load current	16A
Number of phases	1
Accuracy	1 min
Clock backup	100h
Delay	3 sek/24h
Number of programmer setting combinations	16

# 12A 2P Service Switch



## DESCRIPTION

Service switches are designed for use with single-phase and three-phase motors. It is possible to install a safety lock in the 'O' position. The switches are supplied complete with cable glands.

## DIMENSIONS [mm]

Service switch 12A

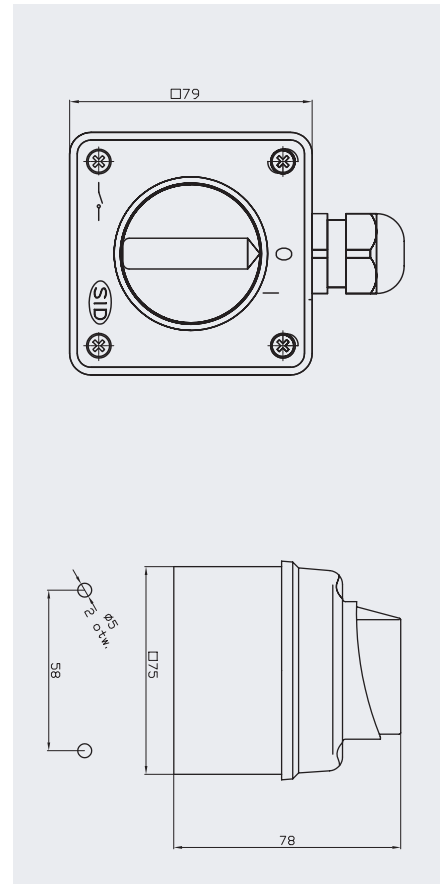

## CONNECTION DIAGRAM

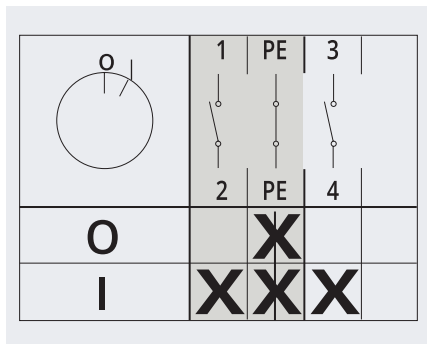

12A switch with PG 13.5 cable glands  
Maximum number of segments: 2

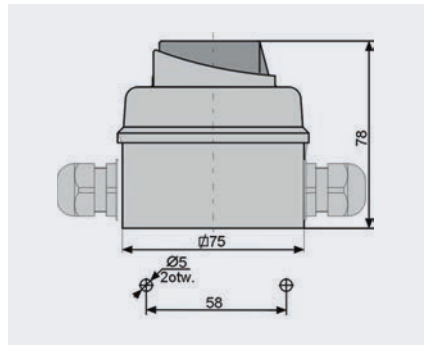

## TECHNICAL DATA

Parameter	
Model	On/off switch
Full name	Service switch 12A 2P
Product code	21714000
Gross weight [g]	207,9
Net weight [g]	160,2
Net weight with glands [g]	183,4
Package dimensions W x D x H [cm]	8,5x8,5x10,6
Number of poles	2
With position O	Tak
Rated continuous current Iu	12 A
Rated operational power for AC-3, 400 V	3 kW
Degree of protection (IP) of front part	IP65
Number of NC auxiliary contacts	Not applicable
Number of NO auxiliary contacts	Not applicable
Number of change-over contacts	Not applicable
For board mounting	Not applicable
For panel mounting	No
For panel mounting	Not applicable
For indirect mounting	Not applicable
Complete unit in enclosure	Yes
Enclosure material	Plastic
Type of actuator	Knob
Type of connection of main contacts	Screw connection

## PDI/PDT Roof Base

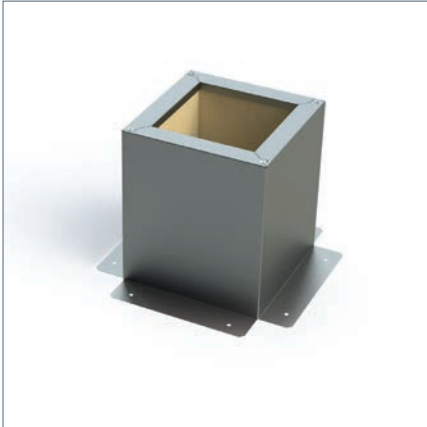

### DESCRIPTION

The roof base for flat roofs is made of galvanised sheet metal. Two types of bases are available: PDI – insulated, with 10 mm thick insulation (polyurethane foam) inside to prevent condensation, and PDT – soundproof, with 30 mm thick insulation (mineral wool). The base can be equipped with additional side outlets (single or double). The standard height of the base is 300, 400 or 500 mm. The product is available in two finishes: galvanised or powder coated in any RAL colour.

### MARKINGS / PRODUCT CODE

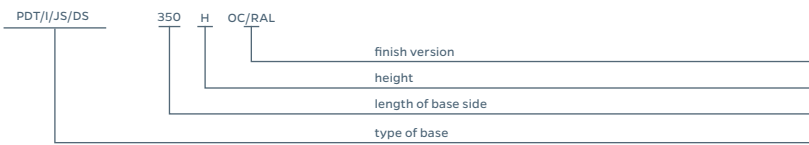

PDT/I - base type: T - damping; I - insulated

JS/DS (if applicable) - additional side outlet. JS - single-sided; DS - double-sided

350 - base side length

H - height: 150, 300, 400, 500 mm\*

OC/RAL - finish version: OC - galvanised; RAL - powder coated

\*in special designs, other base heights are available

### DIMENSIONS

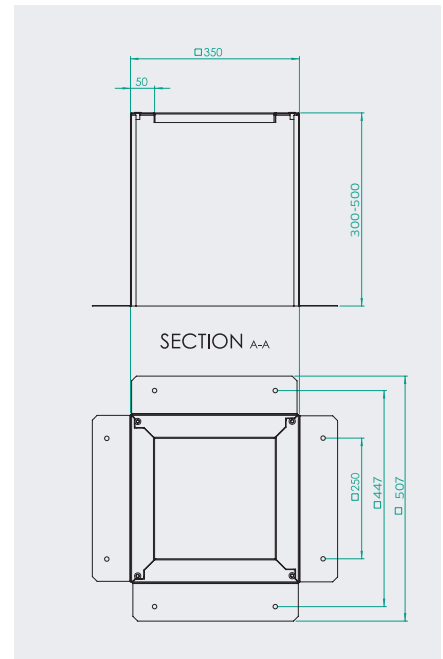

## PA Adaptation plate for PDI/T base



### DESCRIPTION

Base plate with connector (optional). Element closing the bottom of the roof base equipped with a connector with a diameter of 100, 125, 160, 200, 250 or 315 mm.

### DIMENSIONS

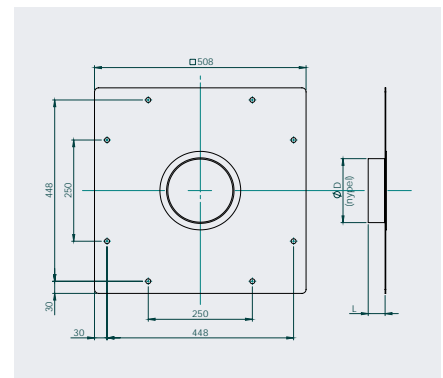

## PMP-A Flat Adaptive Frame

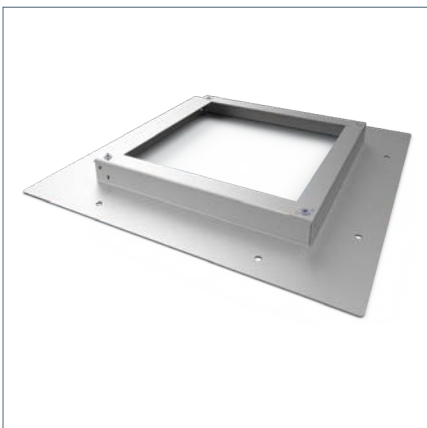

### DESCRIPTION

Adaptive frame for installation with BMV PRO fan, if it is not possible to use the PDI/T roof base.

### DIMENSIONS

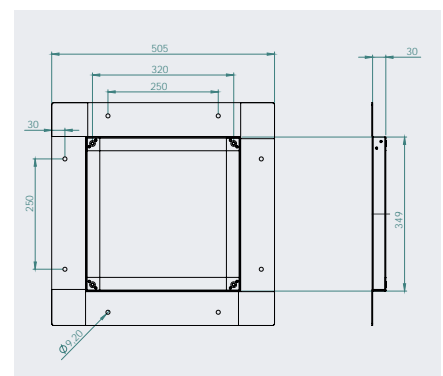

# TLE Flexible acoustic silencers



### DESCRIPTION

The flexible TLE acoustic silencer is made of perforated ducting. The insulation is 25 mm thick and covered with an aluminium-polyester jacket. The silencer is connected with metal flanges that act as nipples. It is available in two lengths: 600 mm and 1200 mm. On request, silencers can be manufactured with EPDM rubber seals, with socket flanges or in various lengths.

### INSULATION:

Insulation type: glass wool, coil-type - flexible.

### TEMPERATURE RANGE:

FROM -20°C TO +140°C

### THERMAL INSULATION OF MINERAL WOOL:

Lambda = 0,034 W/m x k w 24°C.

### PRESSURE LOSSES:

According to the attached diagram.

### FIRE RESISTANCE:

Silencers made of non-combustible materials.

Silencer length 600 mm								
Ød1 nom [mm]	L [mm]	attenuation [dB] for frequencies [Hz]						
		125	250	500	1000	2000	4000	8000
100	600	19	30	27	25	19	10	7
125	600	17	24	22	21	18	10	7
160	600	13	19	18	18	16	7	6
200	600	14	17	12	13	14	7	5
250	600	15	15	10	12	14	6	5

Silencer length 1200mm								
Ød1 nom [mm]	L [mm]	attenuation [dB] for frequencies [Hz]						
		125	250	500	1000	2000	4000	8000
100	1200	29	37	33	36	35	24	13
125	1200	30	36	30	34	32	25	12
160	1200	17	29	28	30	30	23	11
200	1200	24	30	23	26	27	16	10
250	1200	22	23	18	22	19	8	7

50 mm insulation available on request.

### Design version - marking example:

TLE - nipple - this is the standard version  
 TLE-L - a nipple with EPDM gasket installed  
 TLE-F - coupling

### Marking example

Product Code: TLE - 25 - aaa - bbb  
 type .....  
 insulation thickness .....  
 Ø d1 .....  
 L .....

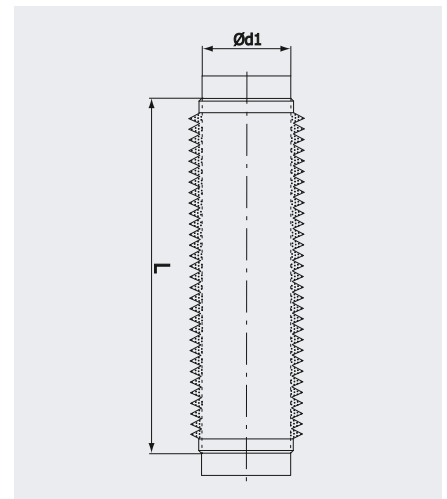

**TECHNICAL DATA**

Pressure loss in TLE-25 flexible silencers.

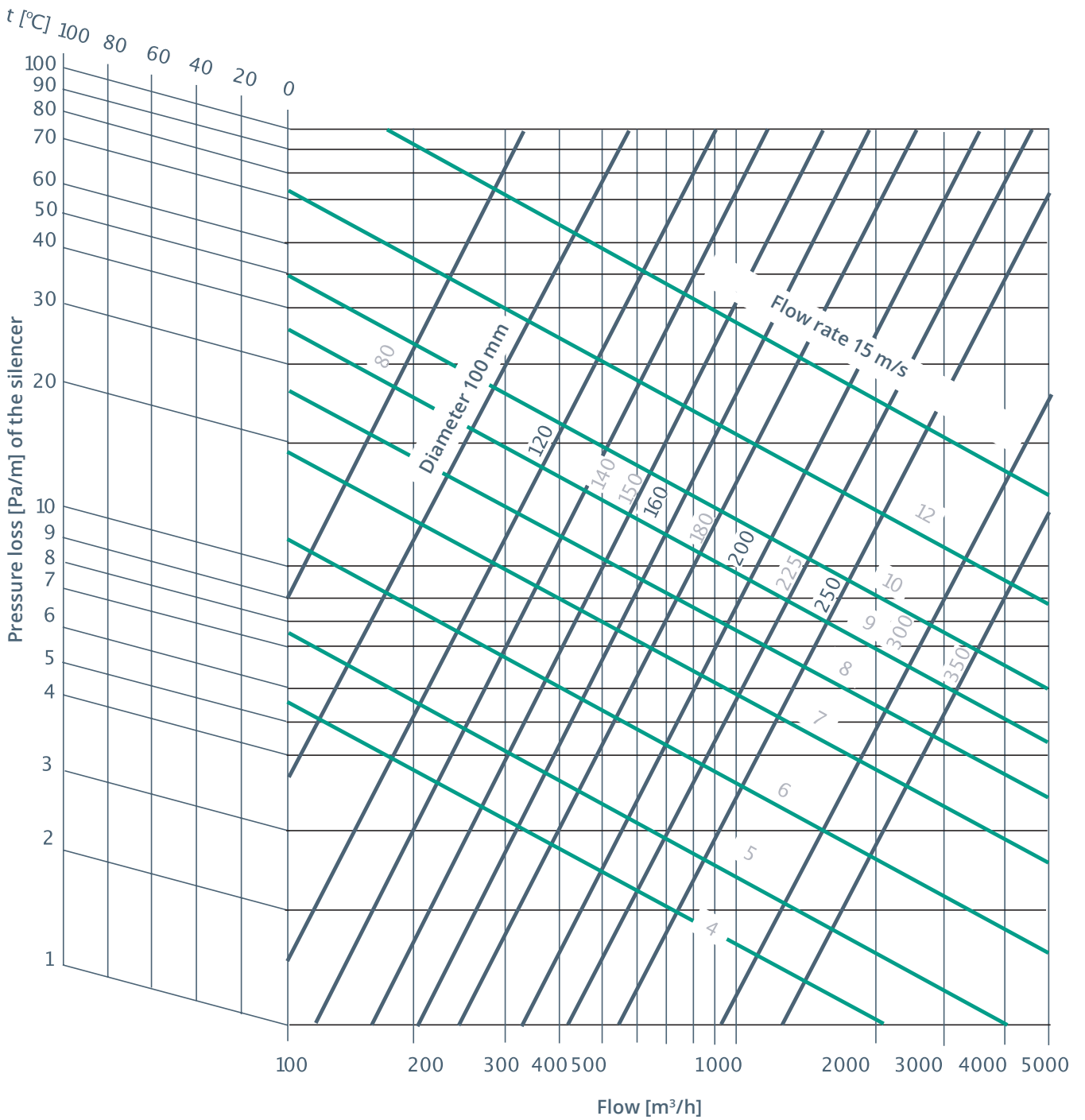

Pressure loss calculated on a stretched and straight silencer.

Silencer length = 1.0 m

1 Pa = 0.01 mbar = approx. 0.1 mm WG

# TLS Rigid acoustic silencers



### DESCRIPTION

As standard, the silencers are supplied with a rubber seal.  
The inside is filled with 50 mm thick mineral wool

### Marking example

Product Code: TLS - 50 - aaa - bbb  
 type -----  
 insulation thickness -----  
 Ø d1 -----  
 L -----

For diameters  $d1 \leq 315$  mm

### DIMENSIONS

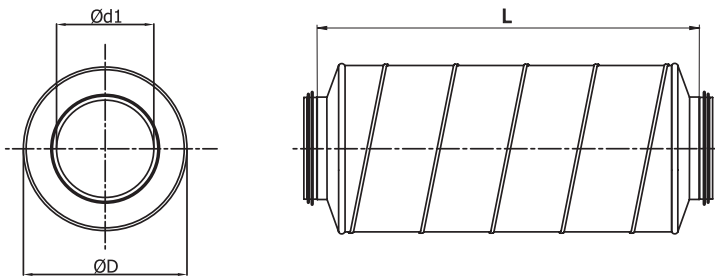

Cross-section for silencers: TLS with 50 mm thick insulation and applies to diameters: D-100 , D-125, D-160, D-200, d-250.  
These are silencers made with pressed lids.

### DIMENSIONS

#### TLS-50 - 50 mm insulation

DESCRIPTION	Ød1 nom [mm]	D nom [mm]	L [mm]	attenuation [dB] for frequencies [Hz]								waga [kg]
				125	250	500	1000	2000	4000	8000		
TLS-50-100-600	100	200	650	9	17	30	45	49	27	29	3	
TLS-50-100-900	100	200	950	12	19	32	48	51	29	31	5	
TLS-50-100-1200	100	200	1250	15	23	35	50	54	32	34	6	
TLS-50-125-600	125	224	650	8	15	27	41	45	24	25	4	
TLS-50-125-900	125	224	950	11	18	29	44	47	26	28	7	
TLS-50-125-1200	125	224	1250	14	21	32	46	50	29	31	7	
TLS-50-160-600	160	250	650	7	14	24	37	39	21	22	6	
TLS-50-160-900	160	250	950	10	16	26	40	42	23	25	8	
TLS-50-160-1200	160	250	1250	13	19	29	42	44	26	27	8	
TLS-50-200-600	200	300	650	6	11	20	35	35	19	20	7	
TLS-50-200-900	200	300	950	8	13	23	38	38	22	23	10	
TLS-50-200-1200	200	300	1250	11	17	26	41	41	25	26	11	
TLS-50-250-600	250	355	650	5	11	19	30	28	16	18	11	
TLS-50-250-900	250	355	950	8	13	22	33	31	19	20	14	
TLS-50-250-1200	250	355	1250	11	17	25	35	34	21	23	17	

### PRESSURE DROPS

#### TLS-50 - 50 mm insulation

DESCRIPTION	pressure drop [Pa] for flow velocity [m/s]				
	2	4	6	8	10
TLS-50-100-600	0,37	1,47	5,88	9,18	13,22
TLS-50-100-900	0,40	1,61	6,45	10,08	14,52
TLS-50-100-1200	1,00	2,00	8,00	13,00	19,00
TLS-50-125-600	0,30	1,20	4,80	7,50	10,80
TLS-50-125-900	0,34	1,34	5,38	8,40	12,10
TLS-50-125-1200	0,00	2,00	8,00	12,00	18,00
TLS-50-160-600	0,25	1,02	4,07	6,36	9,16
TLS-50-160-900	0,29	1,15	4,61	7,20	10,37
TLS-50-160-1200	0,00	2,00	7,00	10,00	15,00
TLS-50-200-600	0,18	0,72	2,88	4,50	6,48
TLS-50-200-900	0,22	0,86	3,46	5,40	7,78
TLS-50-200-1200	0,00	1,00	5,00	8,00	12,00
TLS-50-250-600	0,19	0,77	3,07	4,80	6,91
TLS-50-250-900	0,23	0,91	3,65	5,70	8,21
TLS-50-250-1200	0,35	1,39	5,57	8,70	12,53

# CAR backflow damper



**OPIS**

The airtight non-return damper CAR is used in ventilation systems in circular ducts. It prevents the phenomenon of the so called backflow of air and protects rooms against their cooling in winter.

**APPLICATION**

Particularly suitable for ventilation systems in multi-family buildings on extraction from kitchen hoods, as well as in other ventilation systems.

**DESIGN**

The airtight CAR non-return damper is made of galvanised steel, the damper louvres are made of aluminium. The non-return damper is fitted with an internal gasket to ensure its tightness and reduce noise. An external foam gasket is provided as an additional accessory to ensure easy installation and tightness inside the ventilation ducting.

**DIMENSIONS**

**CAR Ø 100 do Ø 200 mm**

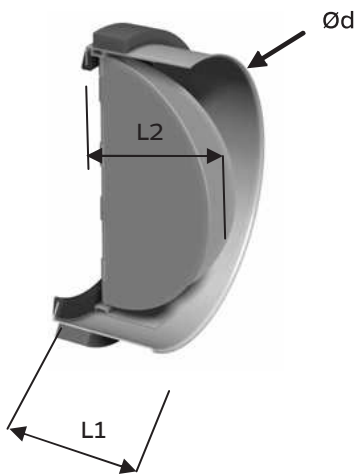

**CAR Ø 250**

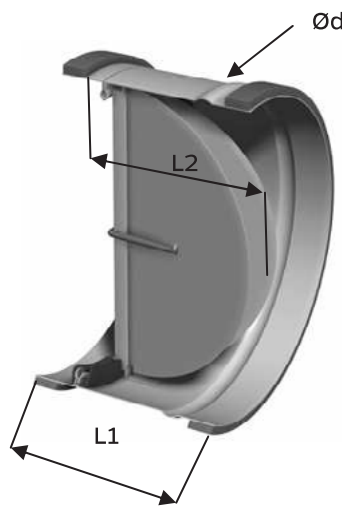

Type	Ød (mm)	L1 (mm)	L2 (mm)
CAR 100	96	43	50
CAR 125	121	49	63
CAR 160	155	66	81
CAR 200	195	72	93
CAR 250	247	120	145

**PRESSURE DROP DIAGRAM**

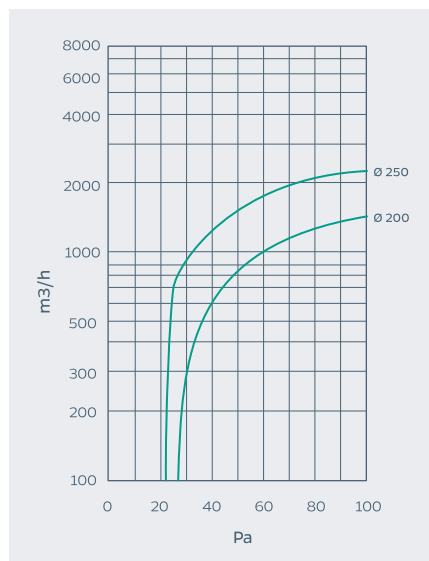
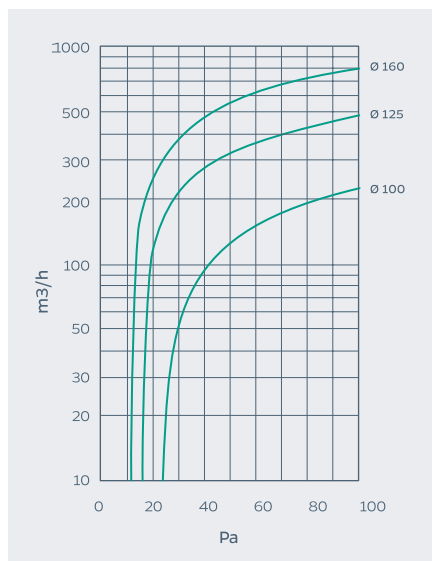

# KFO Duct filter



## DESCRIPTION

The KFO duct filter is used for air filtration in circular ventilation ducting. The casing of the KFO duct filter is a box made of galvanised sheet steel closed from the top with clasps. The casing has mounting spigots with EPDM rubber seals. The special design of the KFO filter allows the filter cartridge to be freely exchanged. It is supplied with an EU3 class filter as standard.

The KFO duct filter can be equipped with a filter element of EU3 or EU5 class. It is possible to order a filter insert in the form of the KFO-I frame filter or the KFO-W pleated filter, which has a filter mat protected by a galvanised steel wire mesh.

## DIMENSIONS

Type	Qd (mm)	AxA (mm)	B (mm)
KFO-100	100	160	150
KFO-125	125	180	150
KFO-160	160	210	150
KFO-200	200	250	150
KFO-250	250	300	150

## Marking example

Product Code: KFO - 160  
 type-----  
 diameter -----

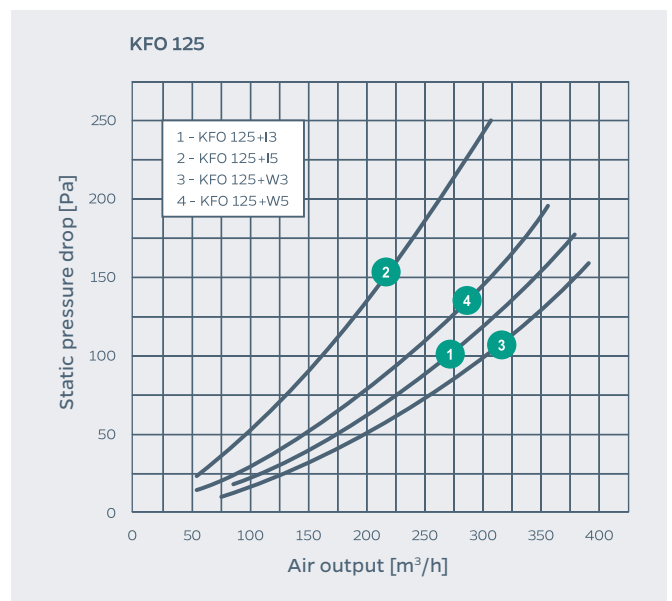
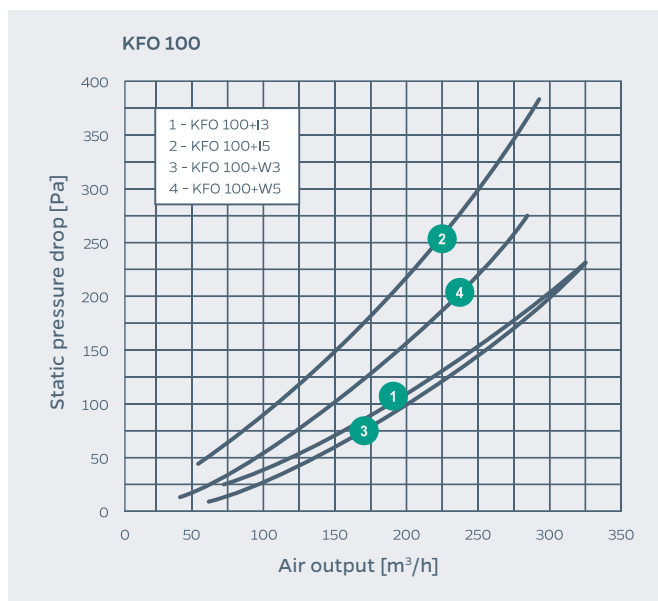
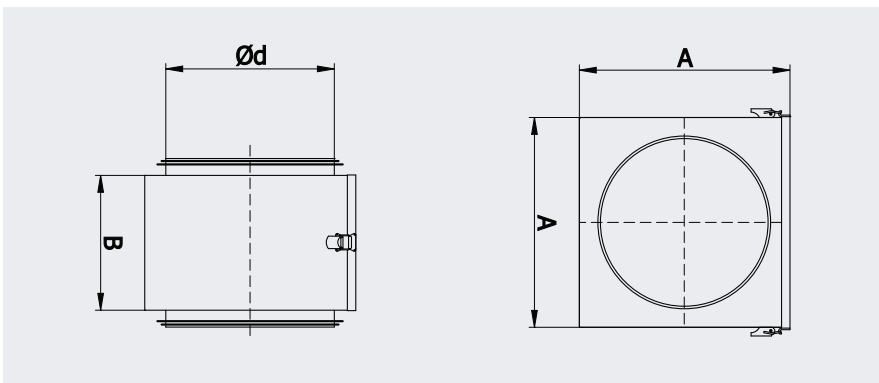

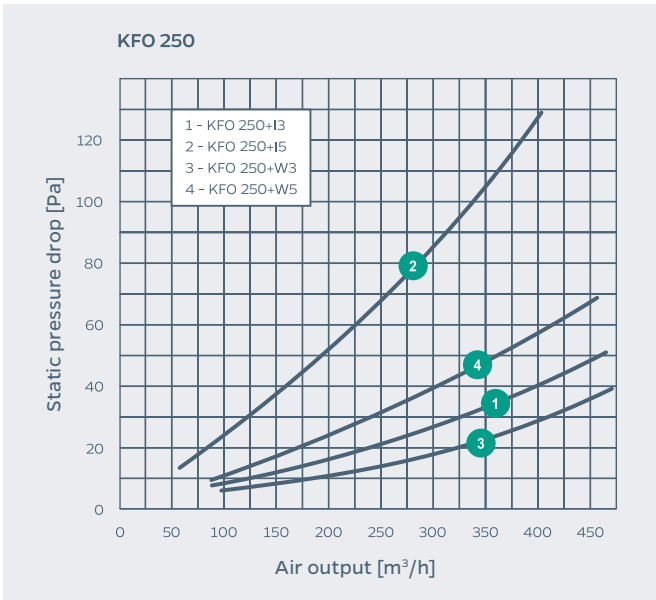
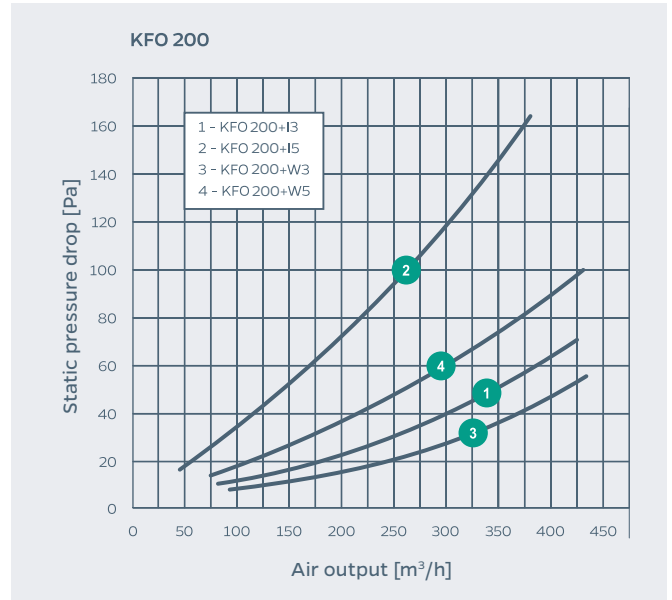
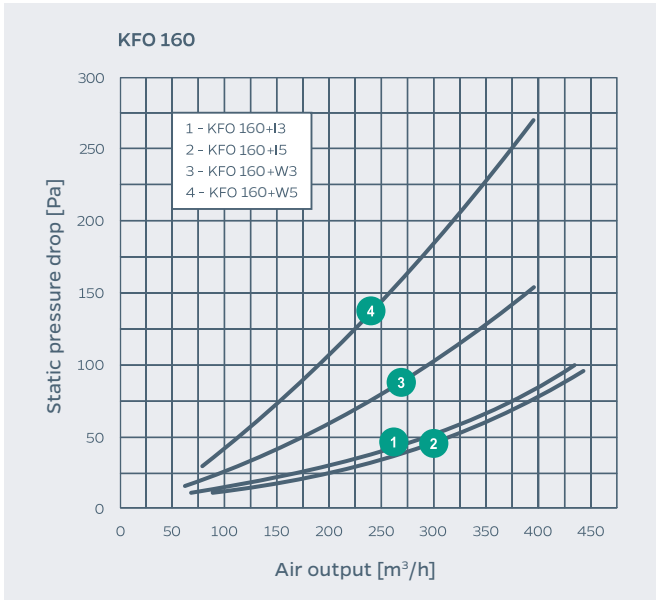

## LE Flexible coupler

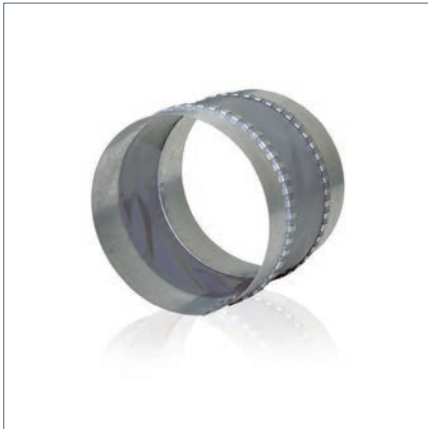

### APPLICATION

Flexible couplers are used for the elimination of vibrations transmitted from the fan or other ventilation devices to the ventilation system, as well as for the partial compensation of ventilation ducting caused by temperature expansions. They are used in ventilation equipment in a temperature range from -40°C to +80°C.

### DESIGN

The flexible couplers are formed by 2 mounting frames, joined to each other by a material insulating vibrations.

### MOUNTING

The installation of the flexible couplers into the ventilation system is carried out using mounting frames. Fastening is carried out using galvanised screws and brackets.

Series	Flange diameter [mm]
LE	100; 125; 160; 200; 250;

### DIMENSIONS

Type	Dimensions (mm)		Weight (kg)
	ØD	L	
LE 100	101	130	0,14
LE 125	126	130	0,17
LE 160	161	130	0,22
LE 200	201	130	0,28
LE 250	251	130	0,35

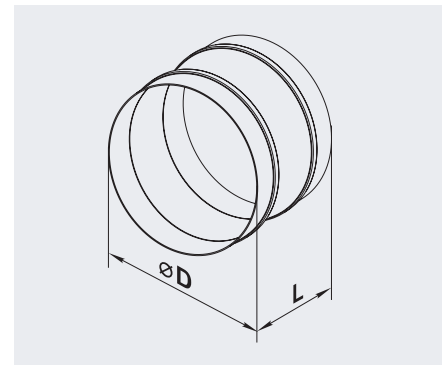



**Brookvent Polska Sp. z o.o.**

Brook House, Dunmurry Industrial Estate,

Dunmurry, Belfast, Co. Antrim, BT17 9HU

M: [hello@brookvent.co.uk](mailto:hello@brookvent.co.uk)

T: +44 (0)28 9061 6505