



# High performance in a compact unit



## *Mechanical Extract Ventilation*

## Installation, maintenance & user manual

Applicable to the following airstream Ace models:

PRODUCT CODE	DESCRIPTION
AS 92-ACE-H-125	airstream Ø125 connection c/w Integral Humidistat
AS 92-ACE-H-204	airstream 204 x 60 connection c/w Integral Humidistat
AS 92-ACE-H-075	airstream Ø75 connection c/w Integral Humidistat
AS 92-ACE-125	airstream Ø125 connection
AS 92-ACE-204	airstream 204 x 60 connection
AS 92-ACE-075	airstream Ø75 connection

## CONTENTS

PLEASE KEEP THESE INSTRUCTIONS WITH THE PRODUCT.  
Please read this manual fully prior to installing the MEV unit.

1.0	Introduction.....	2
2.0	Safety .....	3
3.0	Specifications/ Dimensions.....	4
4.0	Installation .....	9
4.2	Ductwork and Connections .....	11
5.0	Electrical Connections/ Wiring.....	13
6.0	Controls and Settings.....	15
7.0	Maintenance.....	23
8.0	User Operation.....	26
9.0	Trouble Shooting .....	28

## IMPORTANT

This appliance is not intended for use by persons (including children) with reduced physical sensory or mental capabilities, or lack of experience and knowledge, unless they have been given supervision or instruction concerning use of the appliance by a person responsible for their safety.

### 1.0 Introduction

The Brookvent Airstream Ace is a compact and highly efficient Mechanical Extract Ventilation (MEV/CMEV) system, specifically designed for smaller dwellings and apartments.

The system should be run continuously 24 hours a day and should **only** be disconnected by a competent person during service or maintenance.

The system works by drawing stale air from 'wet rooms' such as Bathrooms, WC's and Kitchens and expelling waste air from the home. Simultaneously, fresh air is drawn into the home, through passive vents in the walls or window in each habitable room.

### 1.2 Product Guarantee

This product is guaranteed against defects for a period of 2 years from date of purchase with the first year covering parts and labour and the remaining year covering parts only.

In the instance of a defect, Brookvent may repair the product, replace the product free of charge or refund the cost of the product at Brookvent's own discretion. In terms of installation, operation and maintenance please follow all instructions provided. If this product has been misused, not properly maintained, or handled carelessly it may lead to this guarantee being declared void.

Brookvent does not accept liability for damage caused by non-observance of the installation instructions. Service activities must be carried out by Brookvent or by competent installers using original Brookvent parts. This guarantee does not affect your statutory right as a consumer.

Brookvent operate a policy of continuous innovation and improvement and thus reserve the right to alter product specifications and appearances without notice.

## 2.0 Safety

The following information must be read carefully to ensure safe installation and operation of the Brookvent MEV system.

### 2.1 General Safety

- Do not use this appliance for functions other than those described in this booklet.
- Never touch the appliance with wet hands.
- The unit is only suitable for 230 VAC/50Hz electric mains.
- This unit must be earthed.
- Never modify the fan or electronics, all repairs must be conducted by Brookvent.
- Never connect the power if electronics cover is not fitted.
- Never connect the power if the unit is un ducted.
- Do not store inflammable products in close proximity to the unit.
- If cleaning/ dusting the external surface, do so with a dry cloth only.

### 2.2 Responsibility of the Installer

- Correct Installation, balancing and commissioning of the MEV unit.
- Record measured air flow volumes on each of the valves at High and Low rate.
- Compliance to requirements and local additional rules.
- Explanation of the ventilation system to the user.
- All the above, as set out in Local or national regulations and guidelines.

### 2.3 Responsibility of the Occupant

- Cleaning the valves in the rooms regularly to prevent blockage.
- To ensure that the system is functioning properly on a regular basis.
- To use manual boost switches (where provided) to prevent build-up of pollutants or mould growth.

## 3.0 Specifications/ Dimensions

### 3.01 Ø125 connection

H 398mm x W 388mm x D 268mm

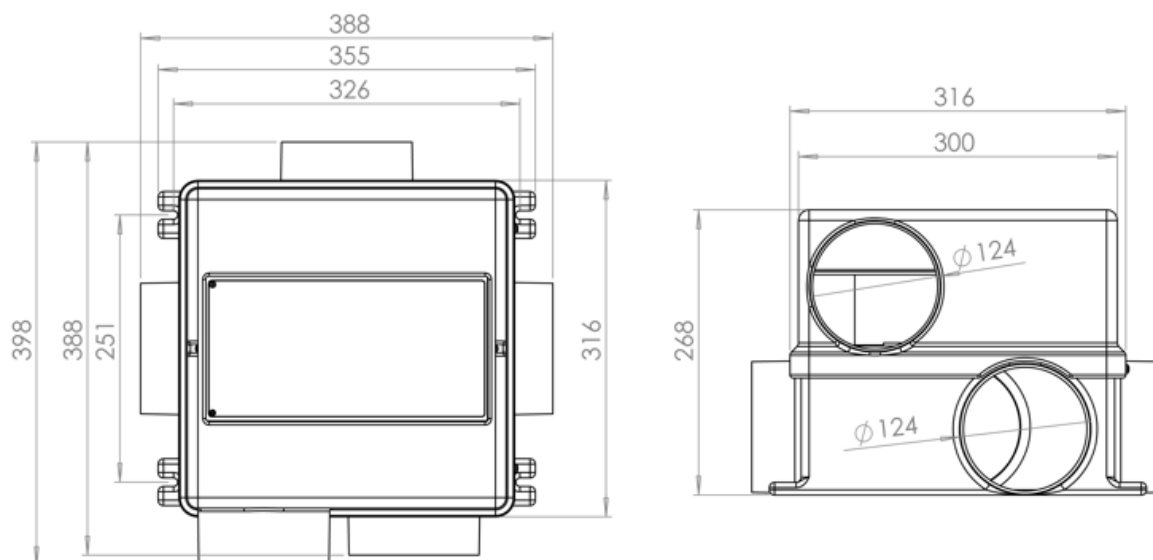

### 3.02 204 x 60 connection

H 388mm x W 374mm x D 246mm

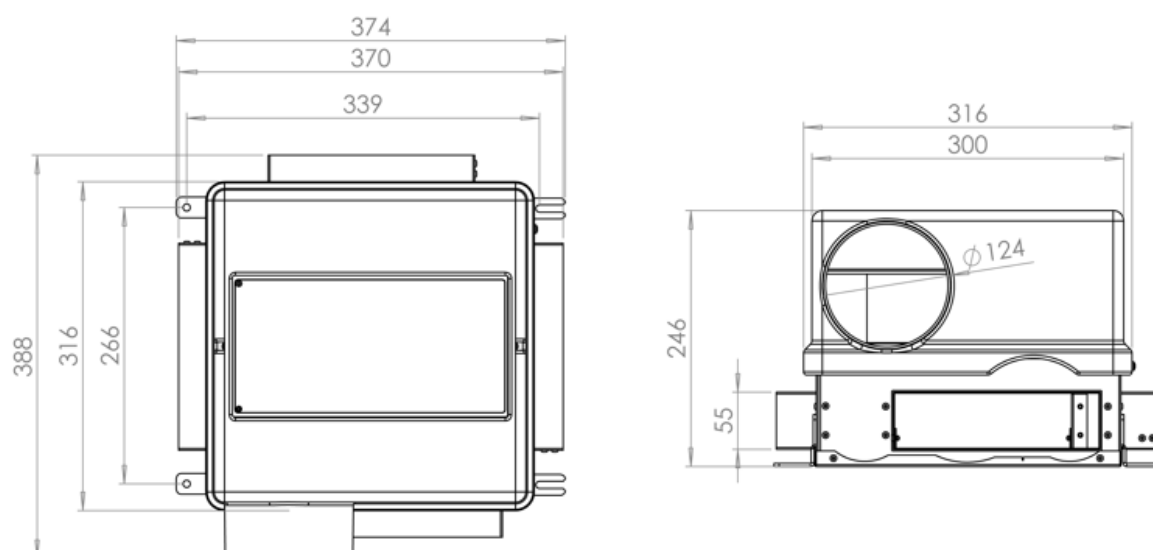

### 3.03 Ø75 connection

H 401mm x W 397mm x D 253mm

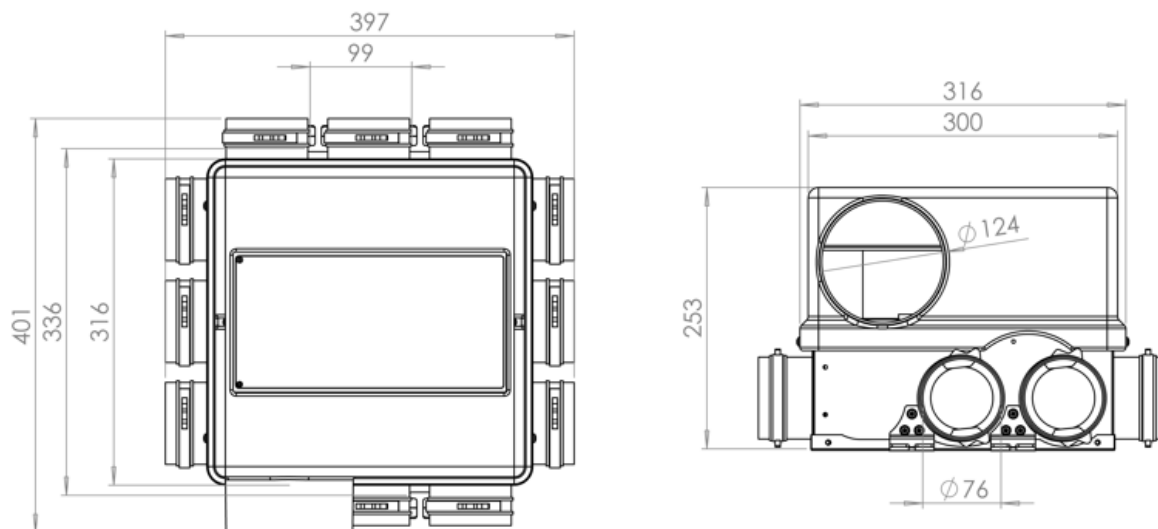

Supplied with 8 spigot and 3 blanking caps fitted (with 5 spare blanking caps)

## 3.1 Duct Connections

### Standard Configuration:

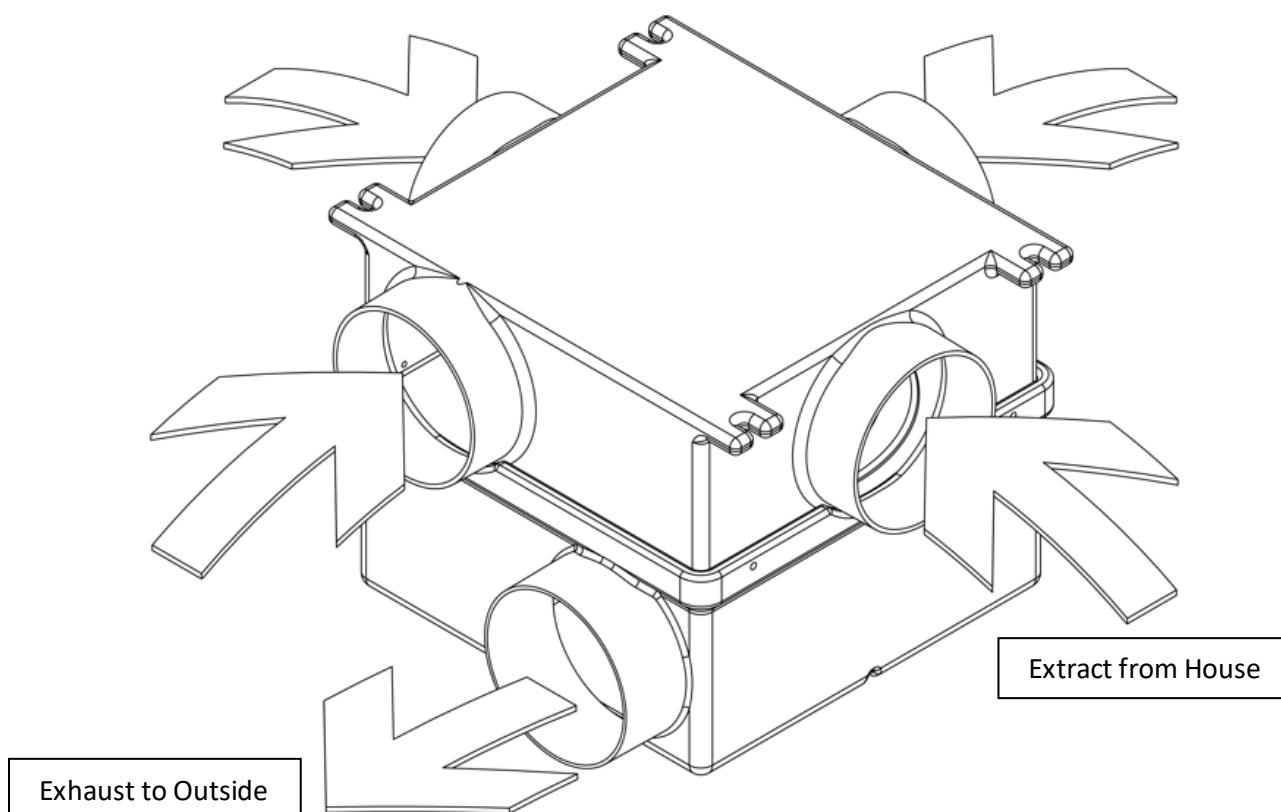

## 3.2 Detailed Specification

Weight: 3.5kg to 4kg (dependant on duct connection)

Materials:

- Main enclosure: Medium Density Polyethylene (MDPE).
- PCB & control panel enclosure: ABS FR.

Electrical:

- 230v EC Low energy, backward curved centrifugal fans.
- PCB c/w potentiometer control for commissioning.
- Supplied complete with 5 core flying lead: (Live: Brown), (Neutral: Blue), (Earth: Yellow & Green), (230v Switched Live (Boost): Grey), (230v Switched Live (Purge): Black).

Controls:

- Independent fan speed control (Trickle, boost and purge settings).
- Single 230v boost input (Light switch, humidistat, PIR, etc.)
- Boost over-run timer, adjustable between 0 - 100 min.
- In-built humidity sensor (Boost activation) Variable: 35% -100% RH, factory set: 70%
- Fan failure indication.
- Communication error indication.

Installation: Wall, Ceiling or Floor Mount

Standards:

Fully complies with Building Regulations for UK & Ireland  
SAP Appendix Q Listed | Energy Savings Trust Best Practice | CE |UKCA

Guarantee Period: 2 Years

### 3.3 SAP Appendix Q Results

Exhaust Terminal Configuration	Fan Speed Setting	Specific Fan Power (W/l/s)
Kitchen + 1 Wet Room	100 % Variable	0.19
Kitchen + 2 Wet Room	100 % Variable	0.19
Kitchen + 3 Wet Room	100 % Variable	0.22
Kitchen + 4 Wet Room	100 % Variable	0.28
Kitchen + 5 Wet Room	100 % Variable	0.33
Kitchen + 6 Wet Room	100 % Variable	0.41

SAP 2009 (See SAP - PCDB for further details) <http://www.ncm-pcdb.org.uk/sap/>

Exhaust Terminal Configuration	Fan Speed Setting	Specific Fan Power (W/l/s)
Kitchen + 1 Wet Room	100 % Variable	0.19
Kitchen + 2 Wet Room	100 % Variable	0.19
Kitchen + 3 Wet Room	100 % Variable	0.22
Kitchen + 4 Wet Room	100 % Variable	0.28
Kitchen + 5 Wet Room	100 % Variable	0.33
Kitchen + 5 Wet Room	100 % Variable	0.41

SAP 2012 (See SAP - PCDB for further details) <http://www.ncm-pcdb.org.uk/sap/>

### AS 92- ACE-(H)-075 airstream Ø75 connection

Exhaust Terminal Configuration	Fan Speed Setting	Specific Fan Power (W/l/s)
Kitchen + 1 Wet Room	100 % Variable	0.20
Kitchen + 2 Wet Room	100 % Variable	0.21
Kitchen + 3 Wet Room	100 % Variable	0.25
Kitchen + 4 Wet Room	100 % Variable	0.29
Kitchen + 5 Wet Room	100 % Variable	0.34
Kitchen + 5 Wet Room	100 % Variable	0.42

SAP 2012 (See SAP - PCDB for further details) <http://www.ncm-pcdb.org.uk/sap/>



### 3.4 Airflow: Pressure/ Performance Curve

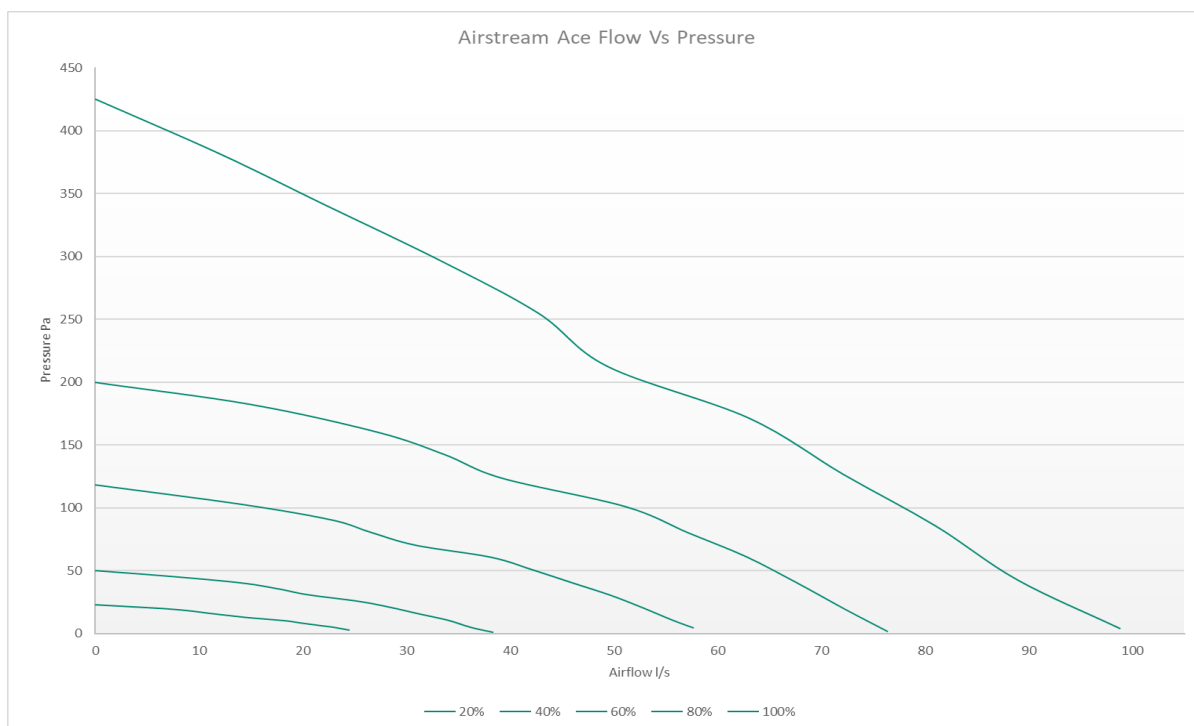

### 3.5 Acoustic Information

		Lf (MAX)							Overall	Overall	Breakout
		125	250	500	1000	2000	4000	8000	Lw	Lwa	dBA @ 3M
Speed 1	Open Extract Duct	41.0	36.8	29.1	23.1	22.2	25.8	46.4	46.0	36.3	20.8
	Breakout	38.3	23.1	21.3	12.9	10.4	13.1	16.5	43.8	30.6	
Speed 2	Open Extract Duct	38.8	34.8	27.9	23.6	20.0	25.3	42.8	42.1	34.6	19.5
	Breakout	19.9	23.1	17.2	10.4	9.1	13.2	26.1	37.8	29.3	
Speed 3	Open Extract Duct	50.7	47.6	35.9	28.4	26.1	26.8	54.6	65.1	58.4	34.5
	Breakout	44.0	40.1	41.3	29.1	27.4	25.9	20.6	50.8	44.3	
Speed 4	Open Extract Duct	59.4	61.8	51.8	46.0	41.1	30.3	65.8	70.4	64.9	39.3
	Breakout	55.2	42.1	45.5	32.6	30.6	29.6	23.1	58.3	49.1	
Speed 5	Open Extract Duct	58.3	58.5	47.5	39.5	35.5	30.8	63.2	70.2	64.9	43.6
	Breakout	45.5	44.3	49.4	36.2	34.4	34.4	27.6	63.7	53.4	

Breakout based on hemispherical propagation at 3m

## 4.0 Installation

It is important that the full installation of this system is carried out by competent persons, including all electrical works and connections being completed by a qualified electrician.

The MEV unit is designed to be installed indoors, within an attic, storage cupboard, or void space, away from exposure to frost, water, or intense heat. The system should be installed in a ventilated space.

A clear access space is required around the unit; this will ensure ease of installation relating to ductwork and wiring. It is important that the system can also be accessed for replacement.

### 4.1 Mounting

Determine the best inlet and exhaust duct configuration to minimise bends close to the unit.

Ensure there is adequate space to allow for maintenance of the unit and for end-of-life replacement.

Fix the unit to the ceiling with fixing 4no. M6 anchors and M6 bolts (not supplied).

Place spigot caps on any of the outlets that are not being used.

Fit the ducting to the spigots and seal using duct sealant and/or aluminium foil tape.

Secure the duct in place with self-tapping screws (pilot hole may need to be drilled) or metal banding and jubilee clips.

#### 4.12 CEILING MOUNT

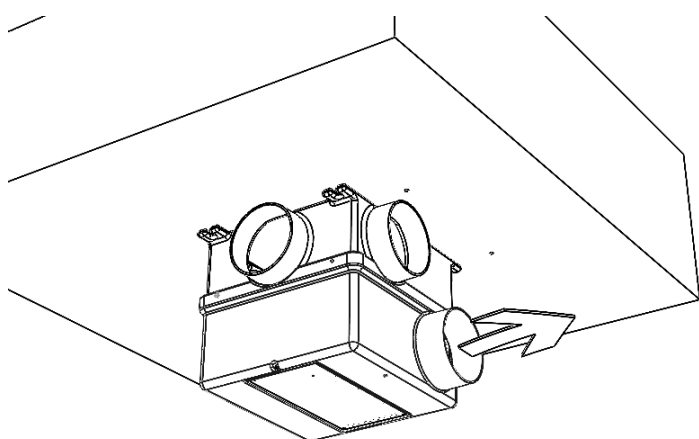

Fig. 1

Please ensure that this method of fixing is suitable for the mounting surface and that it can safely bear the load.

#### 4.13 FLOOR MOUNT

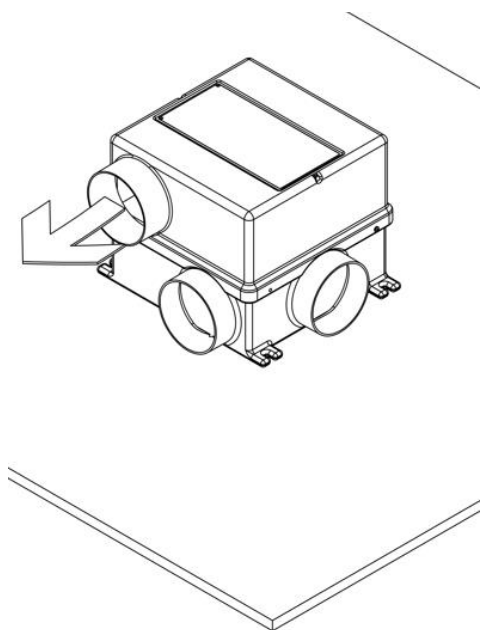

Fig. 2

The unit should be attached to the Floor, as shown, mounted on a raised plinth. (Fig.1).

#### 4.11 WALL MOUNT

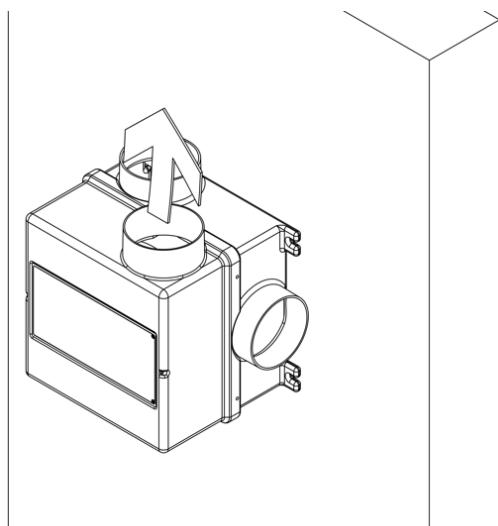

Fig. 3

Please ensure that this method of fixing is suitable for the mounting surface and that it can safely bear the load.

## 4.2 Ductwork and Connections

To comply with SAP Appendix Q, and to facilitate the air flow performance, all ducting used should be rigid or SAP approved semi-rigid duct. If flexible ducting is required, it should be kept to an absolute minimum of 300mm and kept taut as per the Part F Domestic Compliance Guide.

The spigots on the Brookvent airstream Ace systems are suitable for connection to Ø125mm round pipe 204x60 rectangular duct or Ø75 semi rigid duct.

The main exhaust duct connection is Ø125 regardless of which model is used.

For optimum efficiency and performance, it is recommended that 125mm diameter round pipe is used (where possible) to connect to the Exhaust duct run and continue in Ø125 to the exhaust terminal. This will assist in keeping pressure losses to a minimum. A minimum straight run of 300mm should also be used directly off each spigot (where possible).

Where it is not possible to continue throughout the dwelling in rigid 125mm diameter round pipe due to the void spaces available, the use of the AS92-0104-204 model connected with 204mmx60mm flat rectangular ducting should be considered.

It is recommended that the number of bends in the ducting system is kept to a minimum.

The external roof terminal / wall terminal must be the equivalent to the open area of 125mm diameter round pipe (free area of at least 11000mm<sup>2</sup>).

To facilitate air circulation within the dwelling there must be a minimum of 10mm undercut on each of the doors (to the finished floor) within the dwelling (or grills placed at low level on the doors).

Extract air valves (Ø125mm) should be placed in all wet rooms (kitchen, utility, en-suite, etc.) and should be sited, where possible, close to the main source of humidity/ pollutant.

Passive vents should be placed in all habitable rooms (bedroom, living room, dining room, etc.).

Air valves should be locked upon commissioning so that they are tamper proof.

Duct designs/ layouts should always be adhered to if provided.

### 4.3 Anti Vibration Mounting

Where the unit is to be fitted directly above a sensitive room it may be required to install the unit on anti-vibration mounts (provided). Brookvent recommends that all floor mounted MEV's be mounted on anti-vibration mounts.

Work Instruction:

Mark the holes for the Knock in inserts using the unit as the template.

Move the unit clear of the marked positions.

Drill 4 No. holes  $\text{\O}5.6$  to  $\text{\O}6\text{mm}$  holes.

Screw the threaded inserts into place until the top of the insert is flush with the top of the Plinth (part 2).

Screw the 4 No. AV mounts (part 3) into the inserts by hand. Place an M4x20 washer over each AV Mount.

Fit the unit on top of the AV mounts and washers.

Place another M4x20 washer over each AV Mount on top of the bracket. Hand tighten an M4 nut on each AV mount. do not over tighten as this will affect the performance of the AV mount.

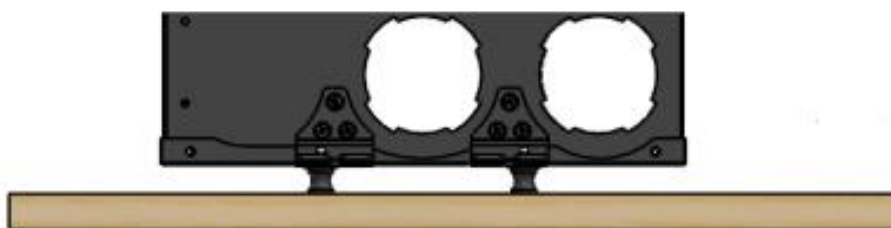
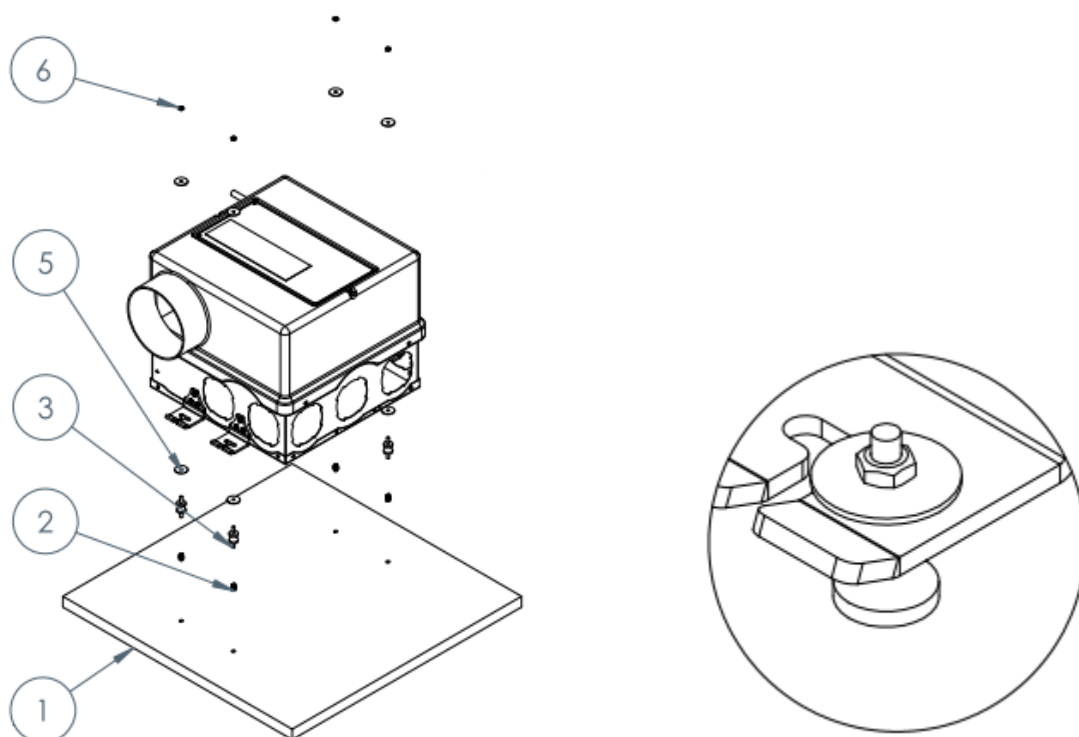

## 5.0 Electrical Connections/ Wiring

### IMPORTANT

All the electrical connections must be carried out by a qualified electrician. Installations and wiring must conform to current IEE regulations (UK), local or appropriate regulations (applying to other countries).

#### Electrical Details:



Voltage: 230 V AC ~

Fuse rating: 3 A

Warning: This unit must be earthed.

Please Note: The 5-core cable from the mains power supply must be connected to a fixed wiring installation, via a **3 amp** fused isolator, as to comply with current IEE wiring regulations.

A switch or circuit breaker must be used in the power supply circuit. It should be in close proximity to the MEV unit and should be clearly marked as the disconnecting device for the MEV Unit.

#### Connecting to mains:

The airstream ACE unit comes pre-wired with 2m length of 5-core cable, which should be connected into a fan-isolation switch. In turn a 3-core mains cable must be used to connect to a **3A fused spur**, which should be located close to the unit. The unit should never be connected to a plug outlet.

The unit also comes pre-connected with a 2m length of alarm cable for connection to the remote display.

L LIVE (BROWN)  
 N NEUTRAL (BLUE)  
 E EARTH (GREEN & YELLOW)  
 SW1 BOOST (GREY)  
 SW2 PURGE (BLACK)

D2 Blue  
 D1 Yellow  
 12V Red  
 0V Black

The switch wires SW1 and SW2 are used to boost or purge the system. When a live 230v signal is applied, the Auto Boost/purge function will be triggered.

5.1

Wiring

Schematic

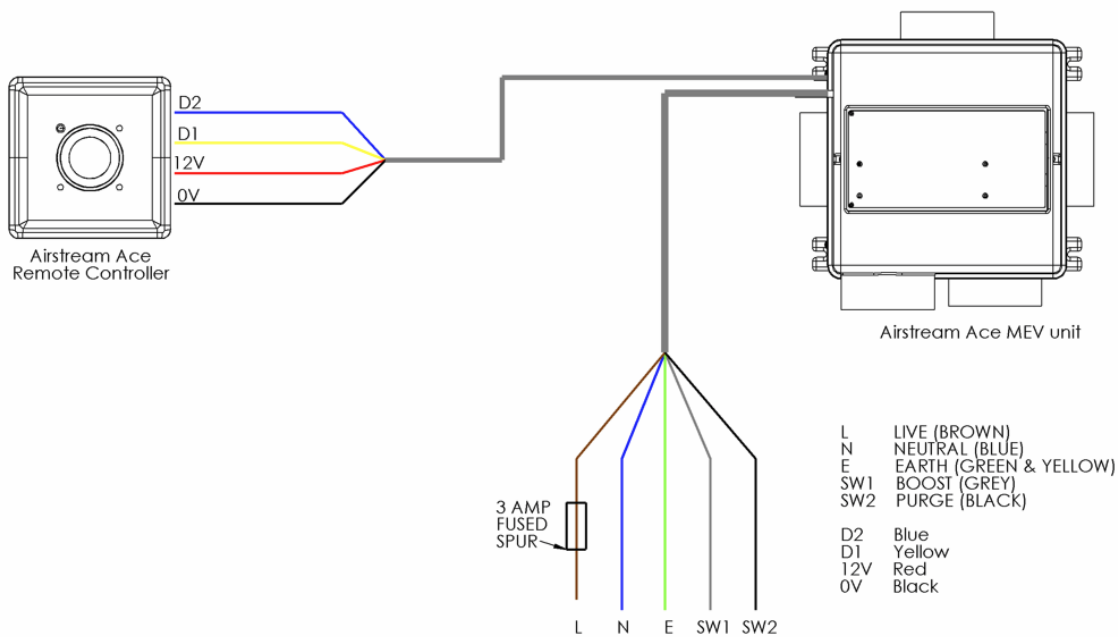

Fig 4

BMS CONNECTION

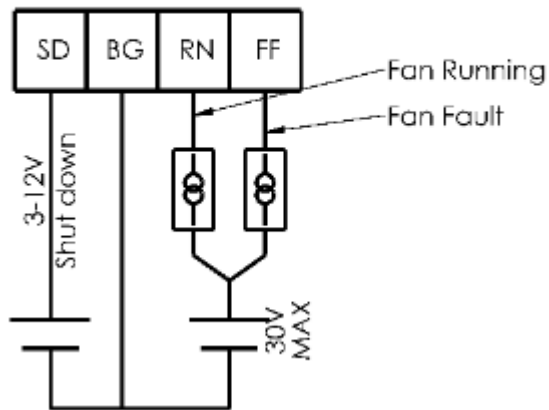

Fig 5 (Optional)

## 6.0 Controls and Settings

### 6.1 Unit commissioning

The fan speeds for each mode along with the humidity setting and over run time settings of the unit are controlled by one potentiometer in the wall switch.

To access the potentiometer to set the speeds, remove the white plastic cover from the front of the wall switch.

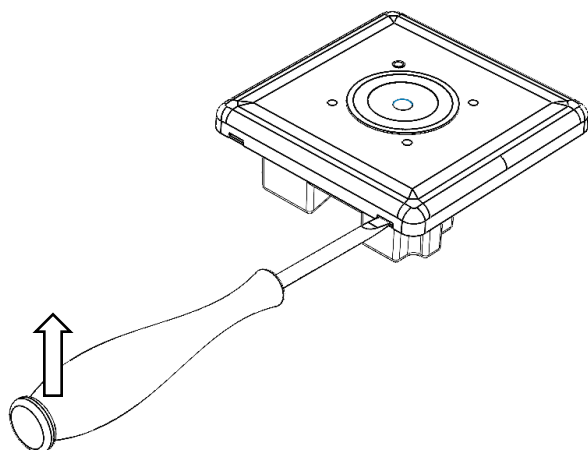

To remove the front cover; insert a small flat screwdriver into the slot shown. Lift the screwdriver up until you hear the click and then repeat for the other slot on the bottom of the switch. Now that the cover has been loosened peel the cover off the switch plate to reveal the controls.

To enter **Set Up**; Press and hold the **SET** key until the centre LED flashes green. This means that the trickle speed can now be set. Using a small flat screwdriver adjust the potentiometer up or down until the required airflow has been achieved.

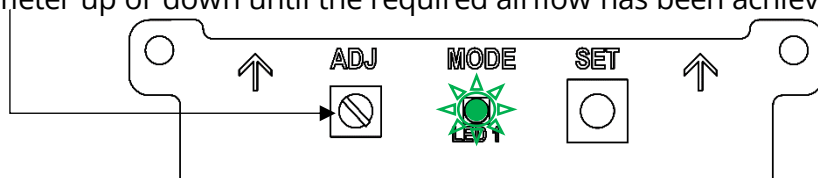



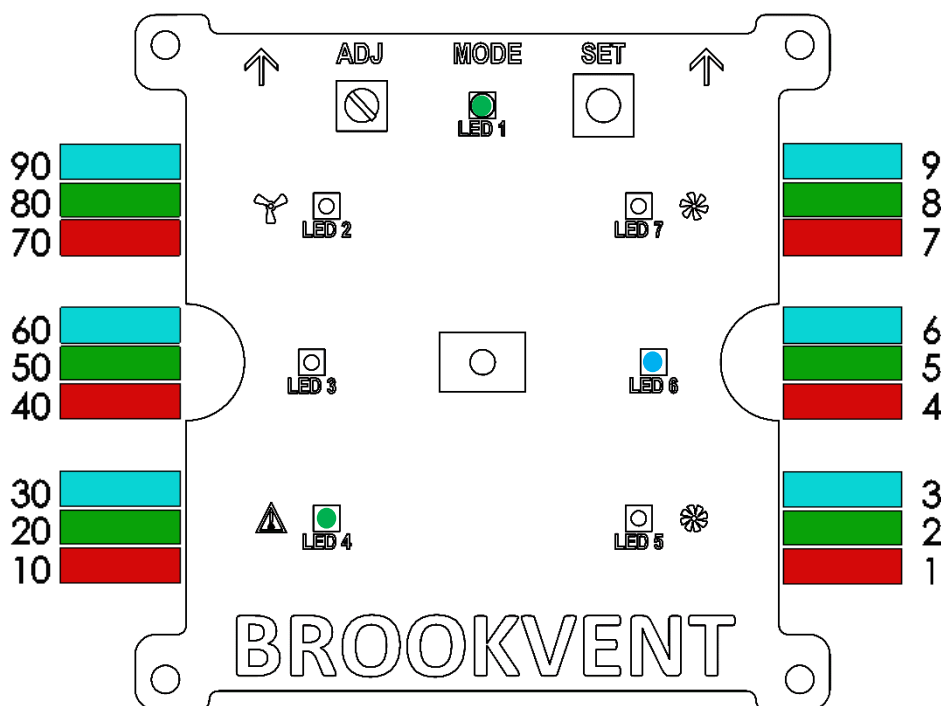

The above example shows the unit set at 26% fan speed in trickle mode.

Press the set button to set the trickle speed and move to the boost speed. The LED will flash blue. Adjust the potentiometer until the desired airflow has been achieved.

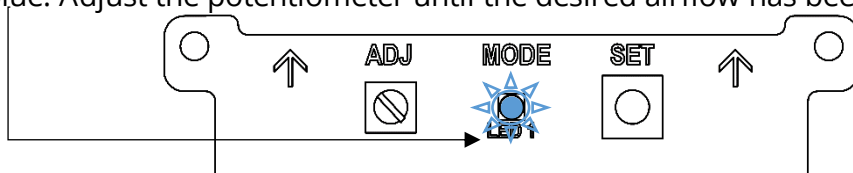

Press the set button to set the boost speed and move to the purge speed. The LED will flash purple. Adjust the potentiometer until the desired airflow has been achieved.

See Fig 6

Press the set button to set the purge speed and move to the boost over run time. The LED will flash Cyan. Adjust the potentiometer until the desired time has been achieved (default 1 min).

Press the set button to set the boost over run and move to the humidity activation level. The LED will flash yellow. Adjust the potentiometer until the desired RH% has been achieved. Press the set button to exit the setup mode.

These separate speed options allow one speed to be set for normal day to day operation (I.e. Trickle) and an increased speed to be set (I.e. Boost) that operates by the pressing the centre button on the wall controller once (colour changes to blue) or when the Sw1 switch wire is triggered by a 230v boost signal such as a Wall Switch or Passive Infrared Sensor.

The system will also go into boost if the set humidity level is exceeded. The internal humidistat will cause the system to boost until the humidity levels have reduced below the set level (only available in models AS 92-ACE-H-\*\*\*).

All boost signals can be cancelled by pressing the centre button on the wall controller until trickle mode is selected (Green light).

If the Boost for the unit is required to be set, it should always be set higher than the Trickle. Adjusting the Speed Pot clockwise increases the fan speed.

Commissioning is carried out to ensure that the required air flows are achieved throughout the property. The volume airflow at each point should be measured using a suitably calibrated Airflow Meter (anemometer), this should be fitted with an adapter/hood to ensure all air is captured and measured by the device.

For the required airflow rates refer to the design specification for the property and or refer to local Building Regulations and /or guidelines.

If further guidance is required on the commissioning process, please contact Brookvent directly.

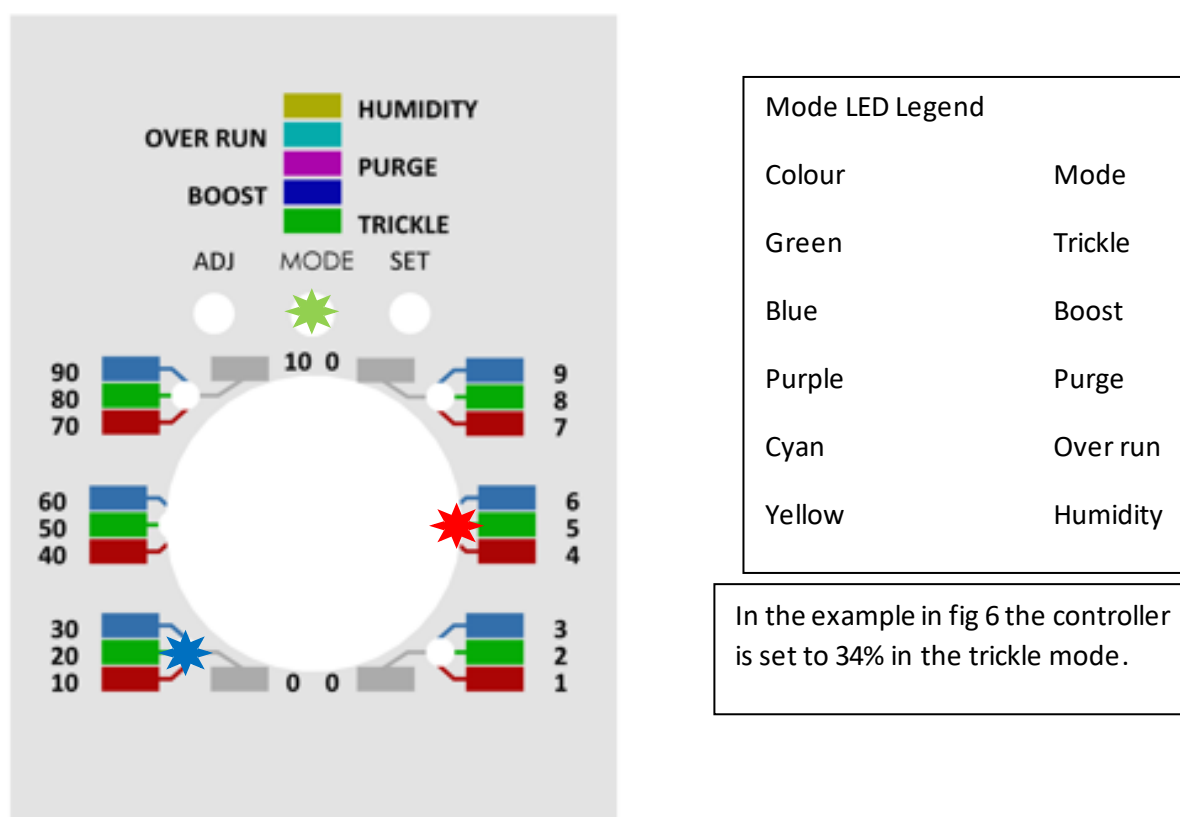
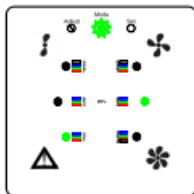
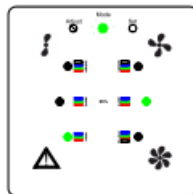

Fig 6. LED Layouts



**Trickle value**  
 When "Mode" flashes Green the value for trickle can be set  
 Range 20%-100%



**Trickle value**  
 If the Adjustment is moved the mode LED stops flashing and the new value is saved with the next press of the set button. Holding the centre button exits the setup process.

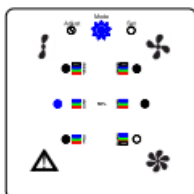

**Boost value**  
 The currently stored value for Boost  
 Range 20%-100%

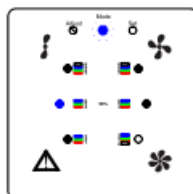

**Boost value**  
 If the Adjustment is moved the mode LED stops flashing and the new value is saved with the next press of the set button. Holding the centre button exits the setup process.

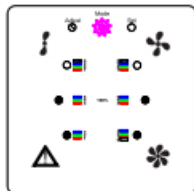

**Purge value**  
 The currently stored value for trickle  
 Range 20%-100%

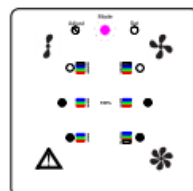

**Purge value**  
 If the Adjustment is moved the mode LED stops flashing and the new value is saved with the next press of the set button. Holding the centre button exits the setup process.



**Over run value**  
 The currently stored Over run time  
 Range 0-100 mins

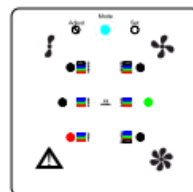

**Over run value**  
 If the Adjustment is moved the mode LED stops flashing and the new value is saved with the next press of the set button. Holding the centre button exits the setup process.

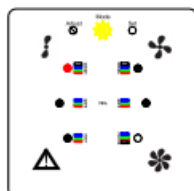

**Humidity value**  
 The currently stored Humidity Value  
 Range 35%-100%

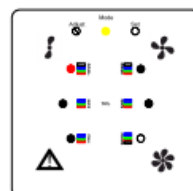

**Humidity value**  
 If the Adjustment is moved the mode LED stops flashing and the new value is saved with the next press of the set button. Holding the centre button exits the setup process.

### Setting the Trickle speed

**Trickle value**  
 When "Mode" flashes Green the value for trickle can be set  
 Range 20%-100%

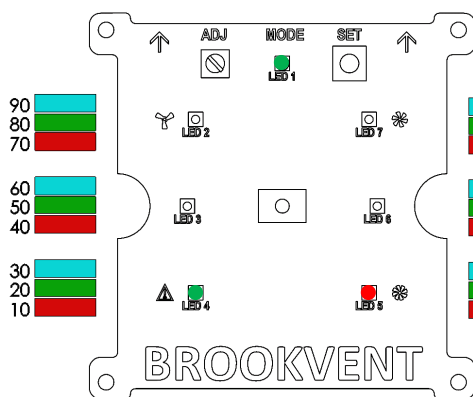

**Trickle value**  
 If the Adjustment is moved the mode LED stops flashing and the new value is saved with the next press of the set button. Holding the centre button exits the setup process.

Above example is set to 21% on trickle.

### Setting the Boost speed

**Boost value**  
 When "Mode" flashes Blue the value for Boost can be set  
 Range 20%-100%

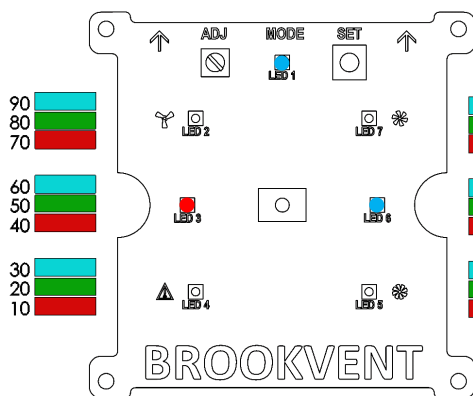

**Boost value**  
 If the Adjustment is moved the mode LED stops flashing and the new value is saved with the next press of the set button. Holding the centre button exits the setup process.

Above example is set to 46% on Boost.

### Setting the Purge speed (default 100%)

**Purge value**  
 When "Mode" flashes Purple the value for Purge can be set  
 Range 20%-100% (default 100%)

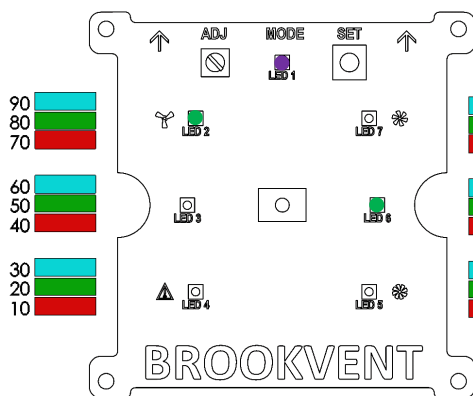

**Purge value**  
 If the Adjustment is moved the mode LED stops flashing and the new value is saved with the next press of the set button. Holding the centre button exits the setup process.

Above example is set to 85% on Purge.

### Setting the over run time (default 1 min)

**Over run value**  
 When "Mode" flashes Cyan  
 the value for over run can  
 be set  
 Over run time  
 Range 0-100 mins

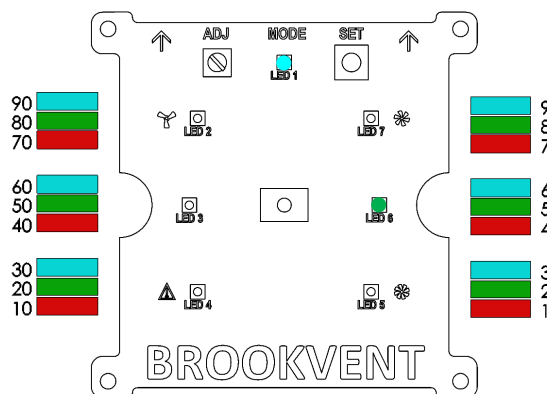

**Over run value**  
 If the Adjustment is moved the  
 mode LED stops flashing and the  
 new value is saved with the next  
 press of the set button. Holding  
 the centre button exits the  
 setup process.

Above example is set to 5 minute over run.

### Setting the humidity level (applicable models only)

**Humidity value**  
 When "Mode" flashes  
 Yellow the value for  
 humidity can be set.  
 Humidity Value  
 Range 35%-100%

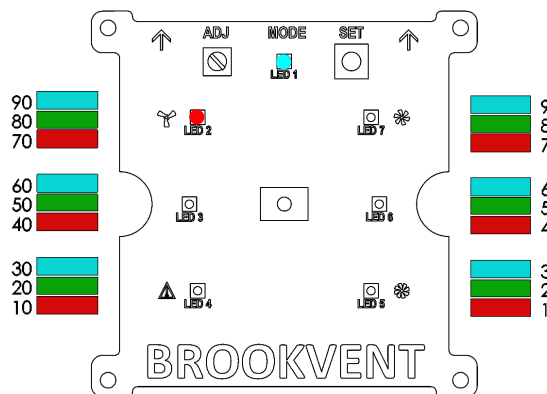

**Humidity value**  
 If the Adjustment is moved the  
 mode LED stops flashing and the  
 new value is saved with the next  
 press of the set button. Holding  
 the centre button exits the  
 setup process.  
 The unit will enter boost mode  
 when the humidity sensor reads  
 the set level of humidity.

Above example is set to 70% Humidity.

## 6.3 Display Modes

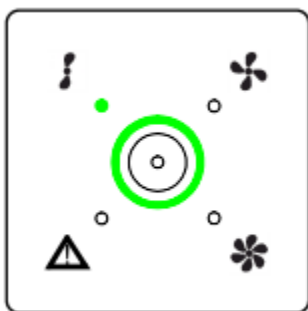

Green light and green inner ring indicate that the unit is running in trickle mode.

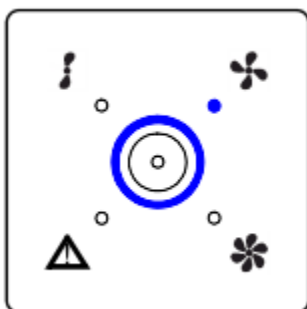

Blue light and Blue ring indicate that the unit is running in boost mode. This can be initiated by the wall controller, the internal humidistat or by any connected 230v signal to the switched live. This mode can be cancelled anytime by pressing the button on the wall controller until trickle mode is reached.

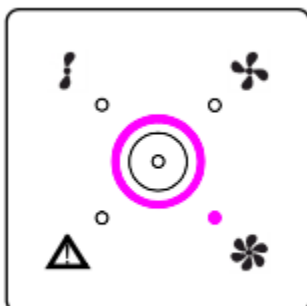

Purple light and Purple ring indicate that the unit is running in Purge mode. This can be initiated by the wall controller, or by any connected 230v signal to the switched live. This mode can be cancelled anytime by pressing the button on the wall controller until trickle mode is reached.



Flashing Blue LED indicates that the boost signal has been switched off and the unit has remained in boost due to the over-run timer (if set). The ring will also flash.

## 6.3 Humidity Control

This feature is set by following the instructions in section 6.1.

Care should be taken when setting the humidity level to account for dilution of the wet air by air extracted from rooms not generating excess humid air; however, setting the value too low may lead to the unit entering boost too often or at inconvenient times.

**The factory setting for humidity is 70% RH.** Turning the Speed Pot clockwise increases the humidity level at which the unit will boost.

**NB.** Upon start-up / power-on, the humidity sensor will be inactive for a period of 60mins due to calibration.

## 6.4 Boost Over-Run Timer

The Brookvent airstream ACE system comes with an adjustable automatic boost over-run timer of up to 100mins (default 1 min). The Grey 'switch wire' on the airstream Ace systems (See section '5.0 Electrical Connections/ Wiring') is used to boost the system. When a live 230v signal is applied by a switch or sensor, the boost function will be triggered. When the signal stops, the boost will over-run for the period set mins as to ensure the system has adequately cleared the pollutants that were present. This is also true for the internal humidistat feature in the airstream ACE.

The boost over-run timer is set as outlined in section 6.1

## 7.0 Maintenance

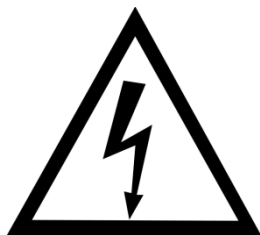

**Warning:** Dangerous Voltage. Before completing any form of maintenance, ensure to isolate the unit from the mains and ensure all supply circuits are disconnected.

This MEV unit may contain connections/signal wires from multiple electrical circuits. **ISOLATING THE CONTROL BOX WILL NOT ISOLATE ALL CIRCUITS WITHIN THE UNIT- PLEASE ENSURE ISOLATION OF ALL CONNECTING CIRCUITS BEFORE ACCESSING THE UNIT.** Examples of other connecting circuits are: electric showers, lighting circuits, and humidistats. These connecting circuits may be used to trigger the auto-boost the system.

It is important to follow all guidelines relating to the maintenance of this MEV system to ensure the unit continues to perform to the levels required.



## 7.1 Fan Replacement

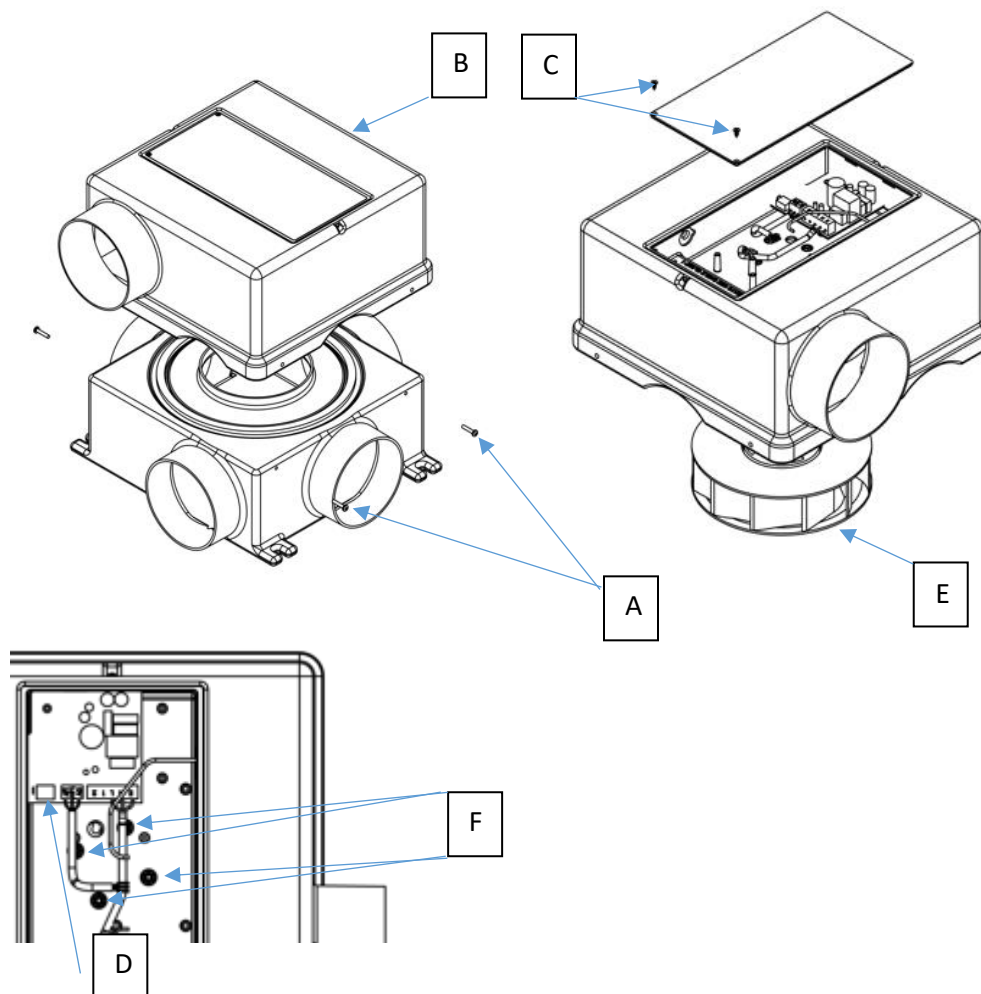

1. Ensure that all power supplies to the unit are isolated including the two switched live cables that may be fed from different circuits.
2. Remove the 4 screws (A) at either side of the unit and remove the fan module (B).
3. Take the lid off the PCB tray by unfastening the two screws C. Unplug the fan mains cable (D).
4. While securely holding the fan (E), remove the 4 fan mounting nuts (F).
5. Take the replacement fan assembly and feed the cable through to the PCB tray. Mount the fan into the unit by lining up the studs on the fan to the mounting holes in the unit. Secure with the 8 fan mounting nuts (F).
6. Reconnect the fan mains (C) and clip the earth cable on the PCB and replace the PCB lid.

7. Refit the fan module to the duct module (opposite of step 2).
8. Power the unit back up and check that the unit is working correctly.

## 7.2 Replacing the PCB

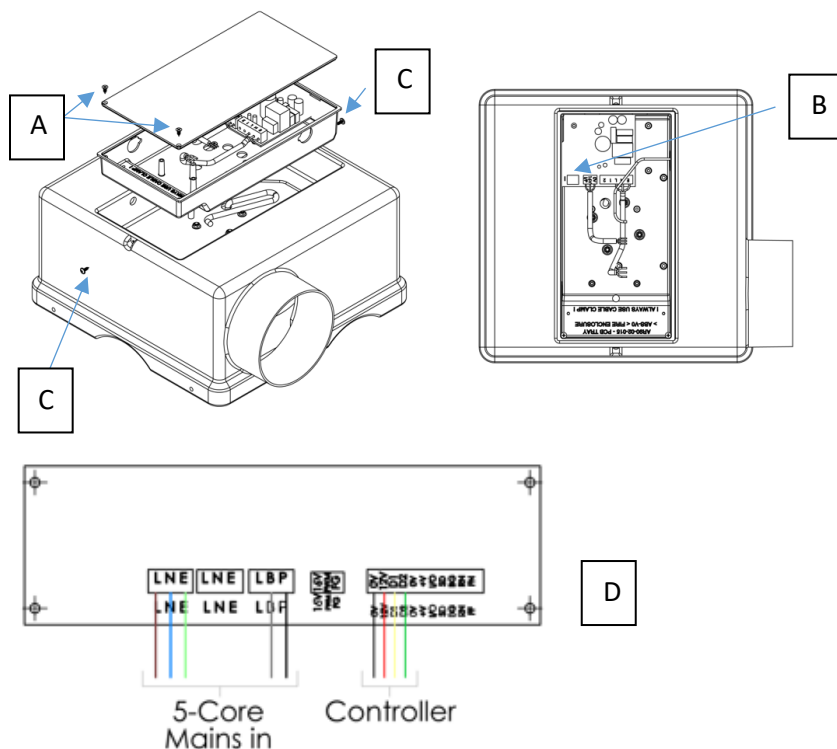

1. Ensure that all power supplies to the unit are isolated including the two switched live cables that may be fed from different circuits.
2. Take the lid off the PCB tray by unfastening the two screws A. Unplug the fan cable (B).
3. Un wire the mains cable, the controller cable and the humidistat cable (if Fitted).
4. Remove the two screws holding the PCB tray in place (C).
5. Remove the whole tray and PCB's from the unit.
6. Place the new tray in the unit feeding the mains, control and humidistat cables through the holes in the side of the tray.
7. Rewire the PCB as per the diagram D. Plug the fan cable into the square PCB.
8. Screw the PCB back in place. Replace the lid on the tray.
9. Power the unit back up and check that the unit is working correctly.

## 7.3 Additional Maintenance Checks

It is recommended that the following checks are also made when completing annual maintenance of the MEV unit:

- Fixings: Ensure that all the unit fixings and the mounting fixings have not become loose over time and are kept sufficiently tight.

## 8.0 User Operation

The Brookvent airstream ACE is an extremely compact and highly efficient Mechanical Extract Ventilation (MEV/CMEV) system, specifically designed for smaller dwellings and apartments with restricted space.

The system should be run continuously 24 hours a day and should only be disconnected by a competent person during service or maintenance.

The system works by drawing stale air from 'wet rooms' such as Bathrooms, WC's and Kitchens, Simultaneously, fresh air is drawn into the home through window or wall vents into the 'habitable rooms' such as bedrooms, dining rooms and living rooms.

It is important that the window or wall vents are left in the open position to ensure good indoor air quality.

How your system is configured upon installation will influence how it can be operated at the user level. Please ensure to refer to the commissioning certificate provided by your installer for full details.

### **General Guidance**

Your system may be set up to boost from trickle speed automatically via sensors (e.g., Passive Infrared Sensors) or manually via simple switch controls. These may be timed switches or push/pull switches. Boost options, if provided and if required, should be used when excess pollutants are being generated within the home (Cooking, Bathing etc.)

With certain dwellings the system may be configured to operate at what is known as a "constant ventilation rate". This means that there is no boost required to adequately ventilate the home and the system always operates at one set level requiring no user input/control.

## 8.1 Typical Automatic Control Options

**Your system commissioning certificate completed by your system installer should detail your automatic control options (if any).**

### **Passive Infra-red (PIR) Sensors**

These are motion sensing switches; these sensors trigger the system into boost mode when activity/ motion is detected in a particular room. They are typically put into sanitary accommodation or bathrooms.

### **Humidistat**

These sensors detect humidity in the air and trigger the system into boost mode when humidity reaches a certain level. These are typically placed in bathrooms or in kitchens. Please note that the aircycle 1.2 system has an In-built humidistat that operates in the same fashion.

### **Light switch**

The lighting circuit of the home can be used to boost the system meaning that when the occupier enters the room and turns the on the light, the system is triggered into boost mode. This is typically used in sanitary accommodation and bathrooms. (note a double pole light switch is required when used to operate the boost function).

\*The items detailed above are examples of the types of Automatic Control Options that are typically used in conjunction with the Brookvent airstream Ace\*

## 8.2 Typical Manual Control Options

**Your system commissioning certificate completed by your system installer should detail your manual control options (if any).**

### **Airstream Ace Wall switch.**

As supplied with the unit. Manual push button used to cycle through the modes.

The switch can be used to cancel any other boost signals and will give information on the operational mode of the unit and if the unit is working correctly.

### Spring loaded switch.

This switch may be placed in any room within the house; however, it is typically used in sanitary accommodation, bathrooms and or kitchens. When pressed, it will trigger the system into boost mode for a defined time.

### Trickle and Boost switch

This is a simple on-off switch with no determined time delay. When the switch is flicked to boost the system goes into its boost state, the switch then must be put back to trickle by the occupier for standard operation. (Please note that the airstream Ace system has an optional boost overrun time of 0-100mins).

\*The items detailed above are examples of the types of Manual Control Options that are typically used in conjunction with the Brookvent airstream Ace\*

## 9.0 Trouble Shooting

### The unit is not running.

Check that the unit is connected to a 3amp fused spur.

Check that there is a live feed to the fused spur.

Check that the 3-amp fuse has not tripped/blown.



The temperature in the unit has exceeded 50°C. The unit will shut down until the temperature reduces.

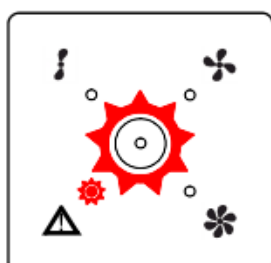

The fan is drawing more or less power than expected indicating that the fan may have failed. Contact a maintenance engineer.



Communication between the controller and the unit has failed during set up.



Main PCB located in the unit has failed to respond to setup request.

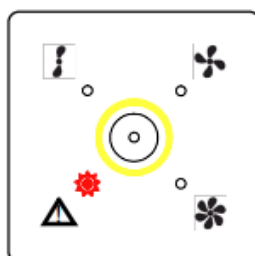

The Humidistat has failed.

If any of the above issues occur:

Press and hold the large centre button until the LEDs turn red. Release the button and then press it again once to restart the system. (Only do this once).

To erase/reset the stored performance data. Remove the front cover. Press and hold the centre button until the fan stops, and the centre ring flashes red. Keep the centre button pressed and then press and hold the set button. After a short delay the ring will flash yellow, and all the other LEDs will light solid yellow. The unit will then reset.

Should either of the above not resolve the issue please contact Brookvent.

### **The system is constantly in Boost?**

New houses can be quite damp with items drying out; this can cause the inbuilt humidistat (and external humidistats) to activate. The in-built humidistat is disabled for the first hour after set up; however, if the system is boosting after this period the level can be adjusted to 100% effectively switching off the humidistat. Remember to turn this stat down again after commissioning.

Check whether the system is designed to boost from a light switch or relay, if so, have any of these been left on while commissioning process is being carried out.

## Notes

---

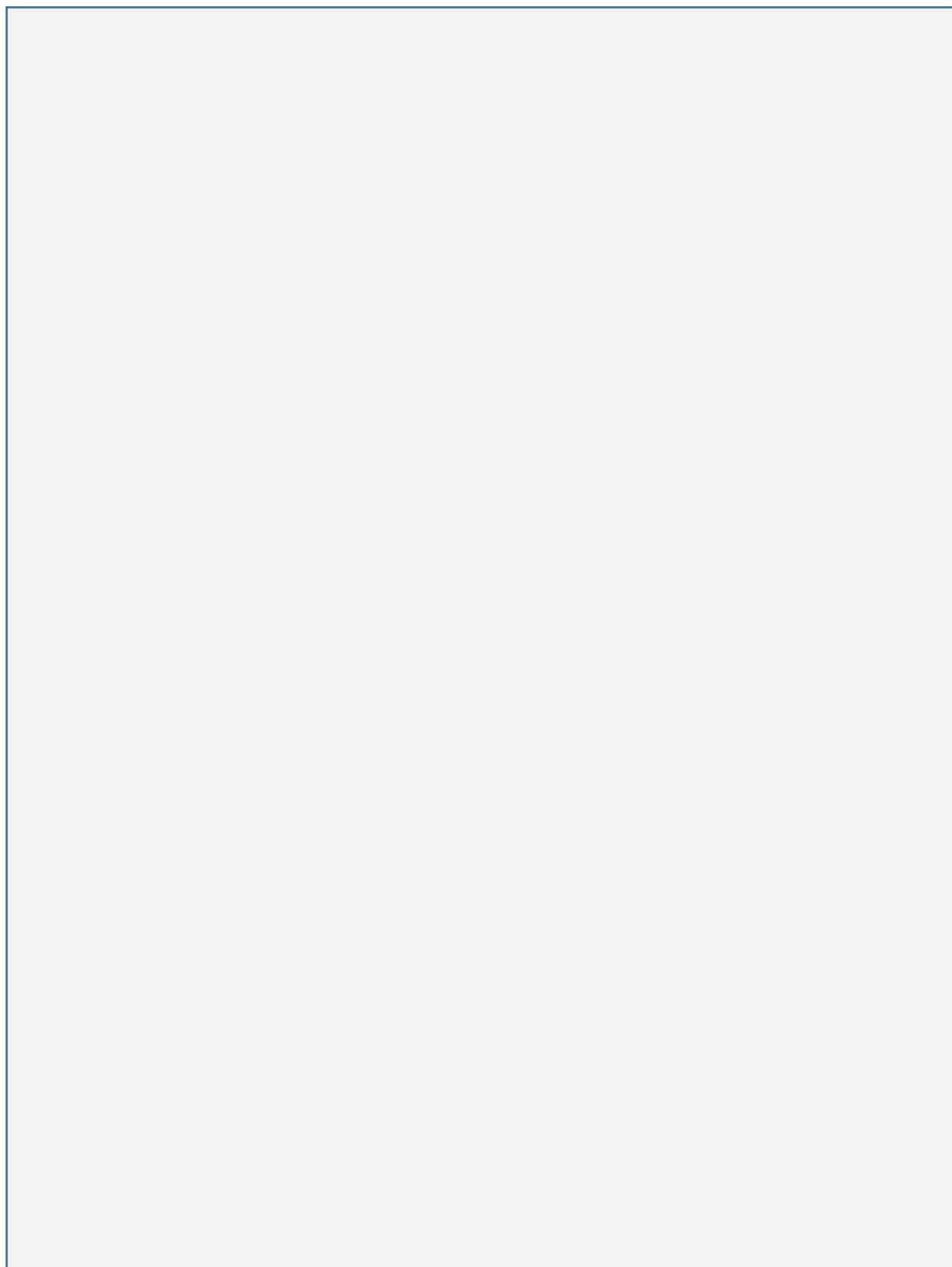

## Customer Support

At Brookvent we pride ourselves on providing Gold Standard after sales and support to all customers. Please feel free to contact one of our specialist team about any query you may have, and we will be more than happy to assist you.

Brookvent  
Brook House,  
Dunmurry Industrial Estate,  
Dunmurry,  
Belfast  
Northern Ireland, BT17 9HU

T: +44 (0) 28 9061 6505

---

It is important to retain this manual and make a copy available to any person using or working with (maintaining) the system.

Brookvent operate a policy of continuous innovation and improvement and thus reserve the right to alter product specifications and appearances without notice.