

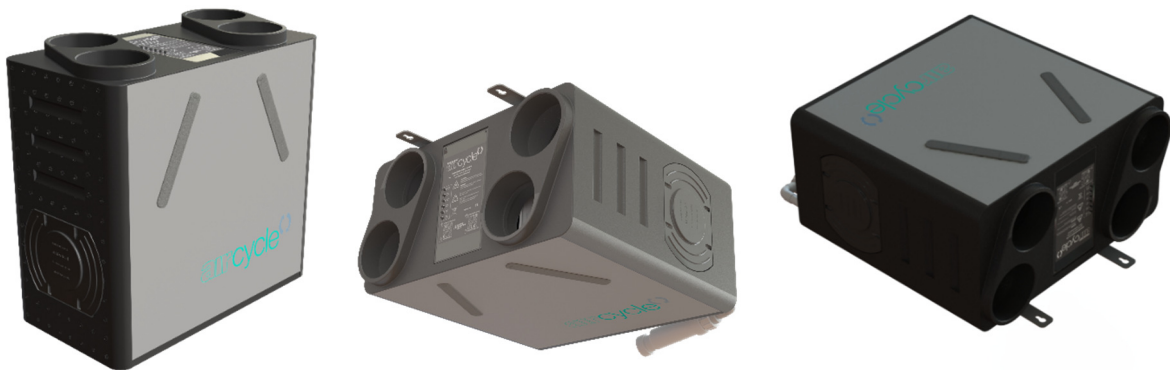

# QUIET, EFFICIENT AND HIGHLY VERSATILE

*Heat Recovery Ventilation*



## Installation, maintenance & user manual

Applicable to the following aircycle 1.3 & 1.3+ models:

<b>aircycle MVHR Product Type</b>	<b>aircycle 1.3 Potentiometer Control</b>	<b>aircycle 1.3+ Potentiometer Control</b>
c/w Humidistat, Bypass - Wall Mount	AS 90-0103-WINS-01	AS 90-0103P-WINS-01
c/w Humidistat, Bypass - Floor Mount	AS 90-0103-FINS-01	AS 90-0103P-FINS-01
c/w Humidistat, Bypass - Ceiling Mount	AS 90-0103-CINS-01	AS 90-0103P-CINS-01

Product codes shown refer to "Standard" duct configuration.  
Add "V" to the end of each product code for an "inverted duct configuration."

## CONTENTS

PLEASE KEEP THESE INSTRUCTIONS WITH THE PRODUCT.  
Please read this manual fully prior to installing the MVHR unit.

1.0	Introduction .....	2
2.0	Safety .....	4
3.0	Specifications/ Dimensions (mm) .....	6
4.0	Installation .....	12
5.0	Electrical Connections/ Wiring .....	21
6.0	Controls and Settings.....	22
7.0	Maintenance.....	27
8.0	User Operation.....	35
9.0	Trouble Shooting.....	40

## IMPORTANT

This appliance is not intended for use by persons (including children) with reduced physical sensory or mental capabilities, or lack of experience and knowledge, unless they have been given supervision or instruction concerning use of the appliance by a person responsible for their safety.

### 1.0 Introduction

The Brookvent aircycle 1.3 is a compact and highly efficient Mechanical Heat Recovery Ventilation (HRV/MHRV) system, specifically designed for smaller dwellings and apartments with restricted space.

The system should be run continuously 24 hours a day and should **only** be disconnected by a competent person during service or maintenance.

Heat Recovery ventilation works best in new homes, which are extremely airtight and have high efficiency ratings. These dwellings require a high level of fresh air to ensure a healthy living environment.

The system works by drawing stale air from 'wet rooms' such as Bathrooms, WC's and Kitchens, recovering up to 92% of the heat from this air using a highly efficient heat exchanger, before expelling waste air from the home. Simultaneously, fresh air is drawn into the home, filtered and warmed by the recovered heat and supplied into the 'habitable rooms' such as bedrooms, dining rooms and living rooms.

## 1.1 Model Variations

<b>aircycle MVHR Product Type</b>	<b>aircycle 1.3 Potentiometer Control</b>	<b>aircycle 1.3+ Potentiometer Control</b>
c/w Humidistat, Bypass - Wall Mount	AS 90-0103-WINS-01	AS 90-0103P-WINS-01
c/w Humidistat, Bypass - Floor Mount	AS 90-0103-FINS-01	AS 90-0103P-FINS-01
c/w Humidistat, Bypass - Ceiling Mount	AS 90-0103-CINS-01	AS 90-0103P-CINS-01

Product codes shown refer to "Standard" duct configuration.  
Add "V" to the end of each product code for an "inverted duct configuration."

## 1.2 Product Guarantee

This product is guaranteed against defects for a period of 5 years from date of purchase with the first year covering parts and labour and the remaining 4 years covering parts only.

In the instance of a defect, Brookvent may repair the product, replace the product free of charge or refund the cost of the product at Brookvent's own discretion. In terms of installation, operation and maintenance please follow all instructions provided. If this product has been misused, not properly maintained or handled carelessly it may lead to this guarantee being declared void.

Brookvent does not accept liability for damage caused by non-observance of the installation instructions. Service activities must be carried out by Brookvent or by competent installers using original Brookvent parts. This guarantee does not affect your statutory right as a consumer.

Brookvent operate a policy of continuous innovation and improvement and thus reserve the right to alter product specifications and appearances without notice.

## 2.0 Safety

The following information must be read carefully to ensure safe installation and operation of the Brookvent HRV system.

### 2.1 General Safety

- Do not use this appliance for functions other than those described in this booklet.
- Never touch the appliance with wet hands.
- The unit is only suitable for 230 VAC/50Hz electric mains.
- Never modify the fan or electronics, all repairs must be conducted by Brookvent.
- Never connect the power if electronics cover is not fitted.
- Never connect the power if either of the fan covers are not fitted.
- Do not store inflammable products in close proximity to the unit.
- If cleaning/ dusting the external surface, do so with a dry cloth only.

### 2.2 Responsibility of the Installer

- Correct Installation, balancing and commissioning of the MHRV unit.
- Record measured air flow volumes on each of the valves at High and Low rate.
- Compliance to requirements and local additional rules.
- Explanation of the ventilation system to the user.
- Warning for the user, to check or replace the air filters on time.
- All the above, as set out in the latest edition of the Domestic Ventilation Compliance Guide and the SAP Appendix Q – Installation Guide and Checklist specific to the UK market.

### 2.3 Responsibility of the Occupant

- Replacement of the filters as per the recommended/ required interval.
- Cleaning the valves in the rooms regularly to prevent blockage.
- To ensure that the system is functioning properly on a regular basis
- To use manual boost switches (where provided) to prevent build-up of pollutants or mould growth.

## IMPORTANT

Dirty or clogged filters may cause inadequate ventilation in the home which may lead to air quality issues. It is important that the filters are changed at least once per year or as required.

In new build properties it may be prudent to check/ change your filters after the first 3 months of occupancy depending on the amount of residual 'building dust' present within the property. Failure to do so will affect your warranty.

Filters can be purchased directly online from [brookvent.co.uk](https://brookvent.co.uk)

## 3.0 Specifications/ Dimensions

### 3.01 WALL MOUNT

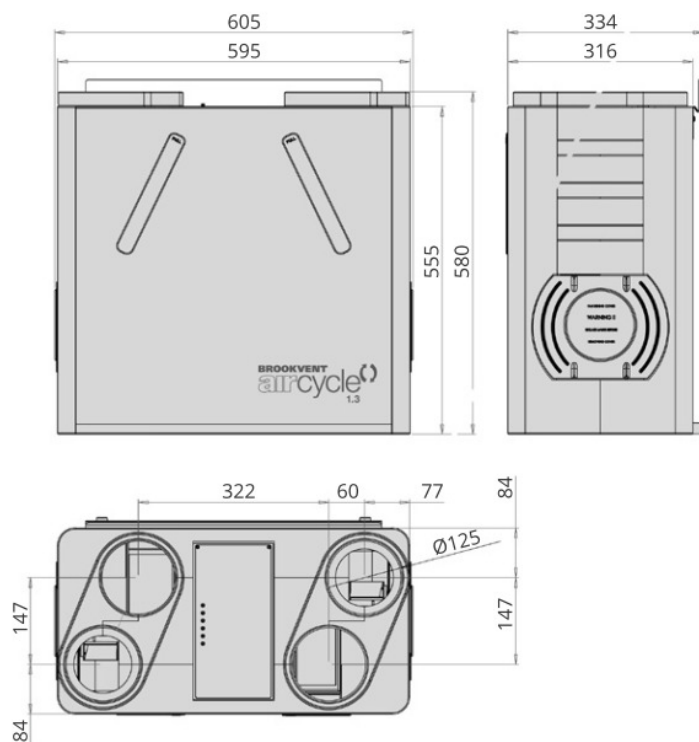

### 3.02 CEILING MOUNT

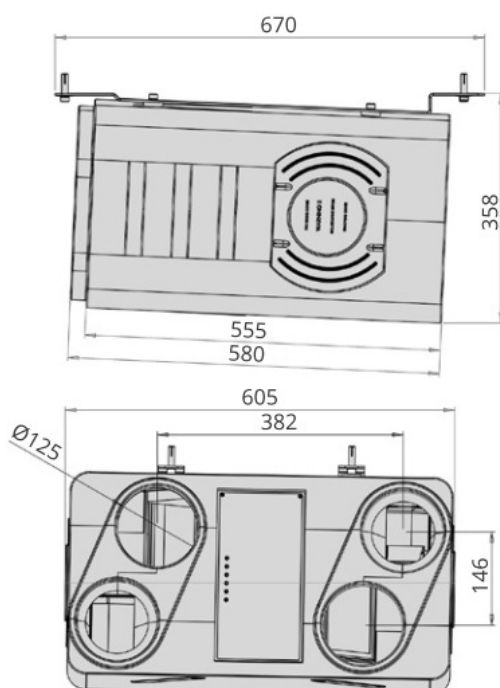

### 3.03 FLOOR MOUNT

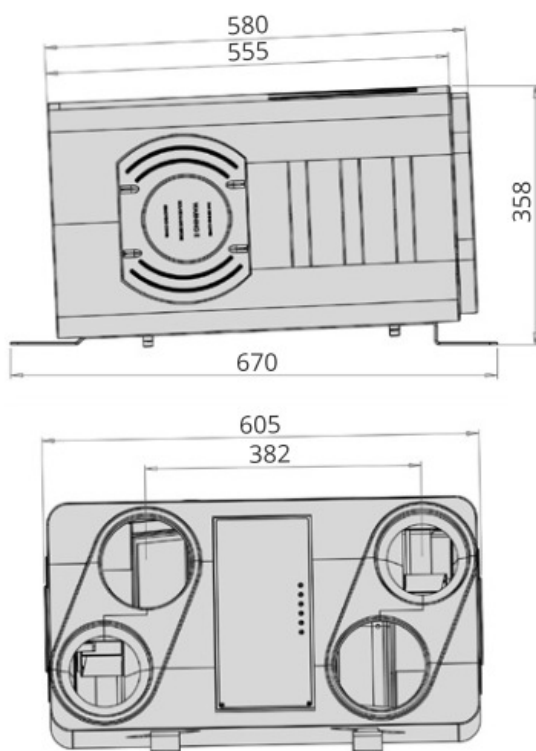

### 3.1 Duct Connections

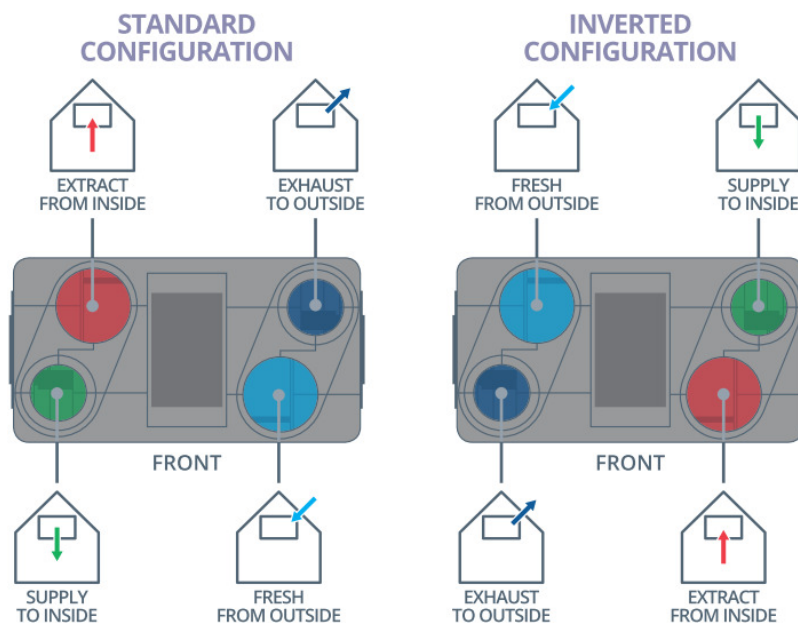

## 3.2 Detailed Specification

Weight: 11kg

### Materials:

- Main enclosure: High density, impact resistant EPP (Expanded Polypropylene)
- PCB & control panel enclosure: ABS FR
- Filters: Polyester media (G3)
- Filter cover: Rubber
- Mounting Bracket: Zinc Plated Steel
- Fan Scrolls: ABS

### Electrical & Controls:

- 230v EC Low energy, backward curved centrifugal fans
- Supplied complete with 5 core flying lead: Live (Brown), Neutral (Blue), Earth (Yellow & Green), 230v Switched Live 1, Boost (Grey), 230v Switched Live 2, Purge (Black)
- Plug and play fan components for easy maintenance

Control Features	Potentiometer Model	Digital Model
Independent fan speed control, 100% variable (Trickle & Boost)	•	• +/- 1%
230v boost input (light switch, PIR, etc.)	•	•
Boost over-run timer (0-15 mins)	•	•
Integral humidity sensor (Boost activation) - Variable RH%, Factory set: 70%	•	• +/- 1%
Frost protection, factory set at 5°C	•	•
Tempering Summer Bypass - Automatic	•	•
100% variable (3rd Purge Speed)		•
Fault alert/ diagnostics		•
Filter check reminder		•
Hours run meter		•
Status indication (Summer bypass, frost protection, etc.)		•
Performance indication (W/l/s, Temp)		•
PIN Protect engineering settings		•
Commissioning settings upload		•
Night mode		•

### Standards:

Fully complies with Building Regulations for UK & Ireland  
 SAP Appendix Q Listed | Energy Savings Trust Best Practice | CE

## 3.3 SAP Appendix Q Results

Model	Aircycle 1.3				Aircycle 1.3+			
	Specific Fan Power (W/l/s)		Heat Exchange Efficiency (%)		Specific Fan Power (W/l/s)		Heat Exchange Efficiency (%)	
	SAP 2009	SAP 2012	SAP 2009	SAP 2012	SAP 2009	SAP 2012	SAP 2009	SAP 2012
Kitchen + 1 Wet Room	0.51	0.57	92	90	0.42	0.45	88	87
Kitchen + 2 Wet Rooms	0.54	0.68	90	87	0.43	0.54	87	84
Kitchen + 3 Wet Rooms	0.63	0.85	88	85	0.5	0.67	85	83
Kitchen + 4 Wet Rooms	0.75	1.1	86	84	0.6	0.87	84	81
Kitchen + 5 Wet Rooms	0.91	-	85	-	0.72	-	83	-
Kitchen + 6 Wet Rooms	1.08	-	84	-	0.85	-	81	-

### 3.4 Airflow: Pressure/ Performance Curve – aircycle 1.3

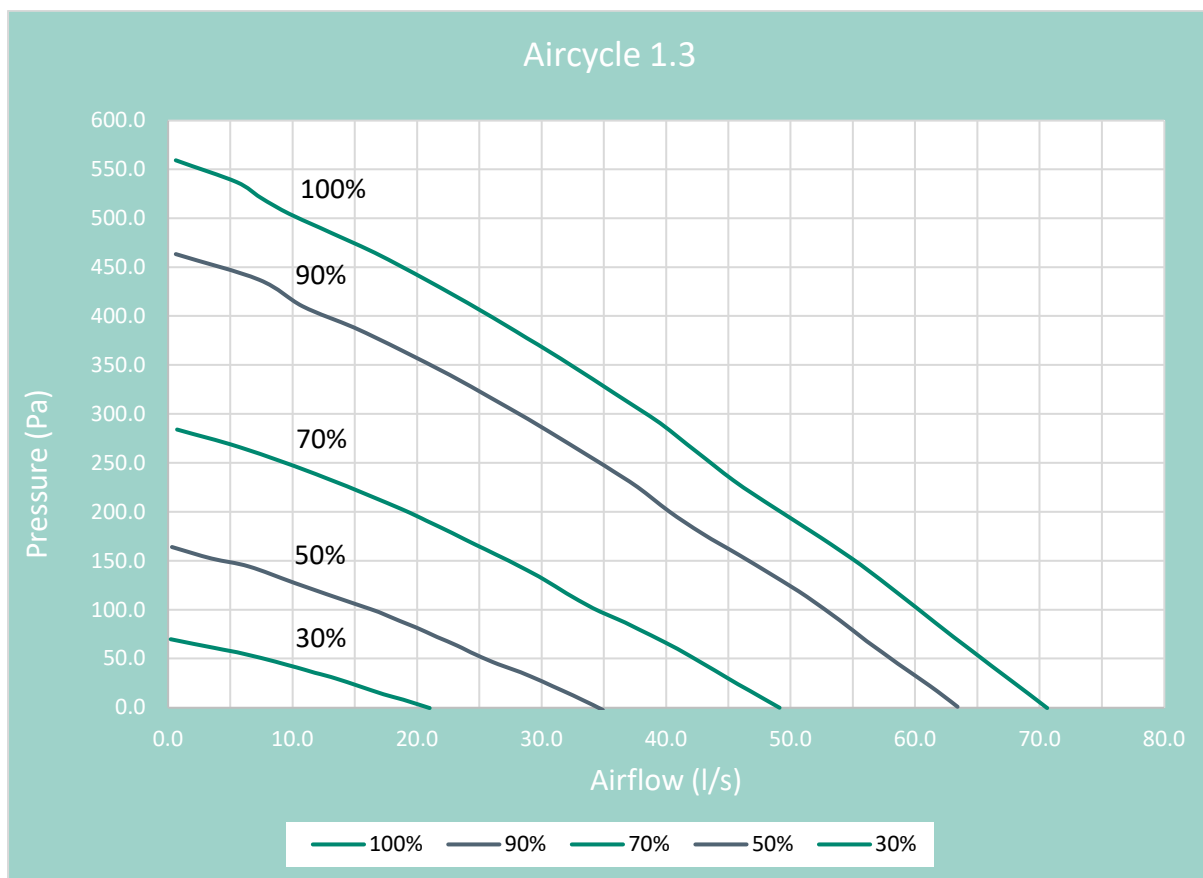

### 3.5 Airflow: Pressure/ Performance Curve – aircycle 1.3+

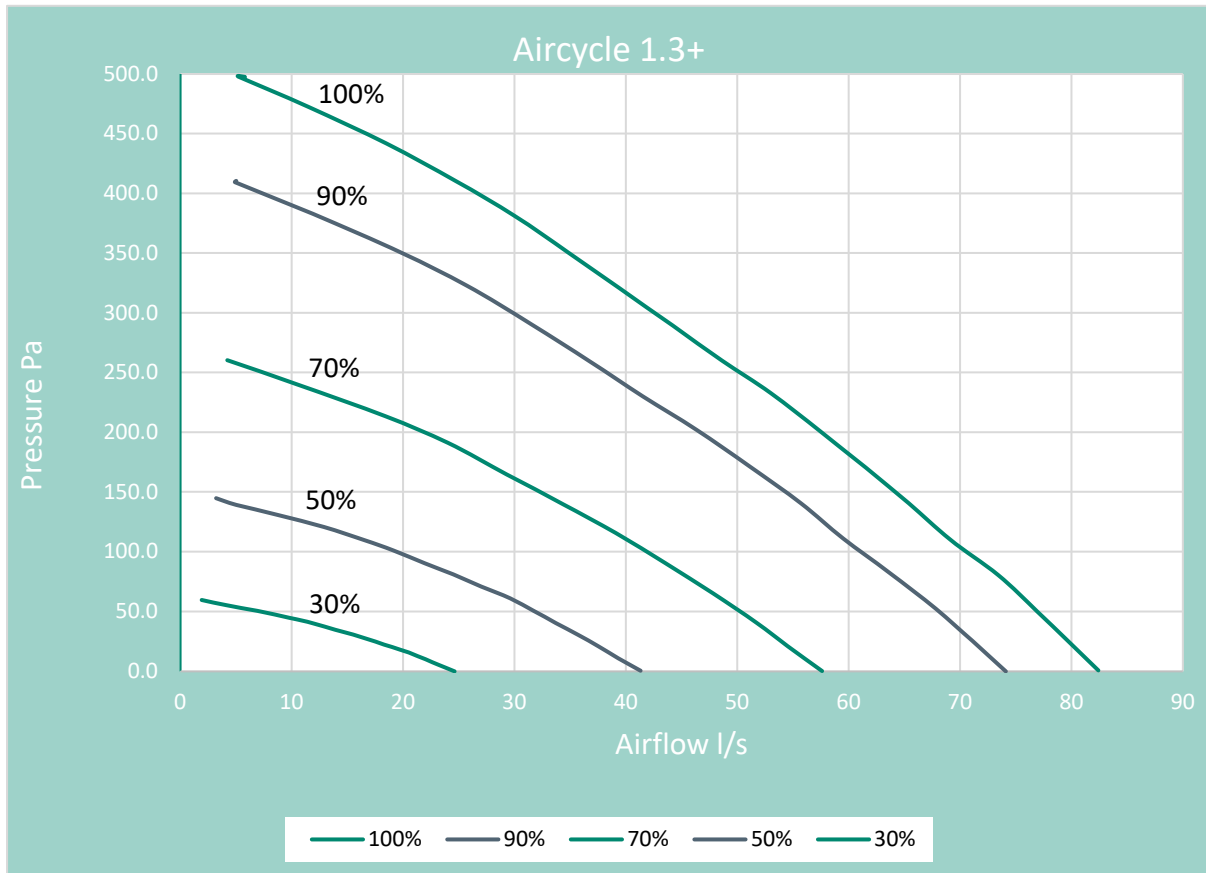

## 4.0 Installation

It is important that the full installation of this system is carried out by competent persons, including all electrical works and connections being completed by a qualified electrician.

The MVHR unit is designed to be installed indoors, within an attic, storage cupboard, or void space, away from exposure to frost, water, or intense heat. The system should be installed in a ventilated space.

A clear access space is required around the unit; this will ensure ease of installation relating to ductwork, wiring, and the connection of the condensate drain. It is important that filters to the system can also be accessed for replacement.

## 4.1 Mounting

### 4.11 WALL MOUNT

The unit should be attached to the wall as shown using the wall bracket provided, please ensure the mounting surface can safely bear the load of the unit using suitable screw fixings.

One bracket will be secured to the back of the unit as shown in **Fig. 1**, the second bracket should be secured to the mounting surface as shown in **Fig. 2**. Please ensure the brackets are level. The unit can then be set onto the mounting surface with the lip of each bracket intersecting as shown in **Fig. 3**

Fig. 1

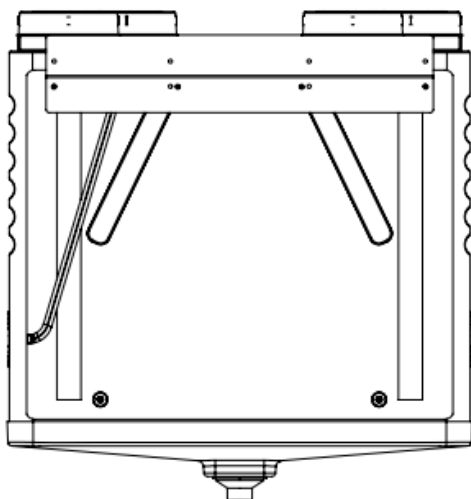

Fig. 2

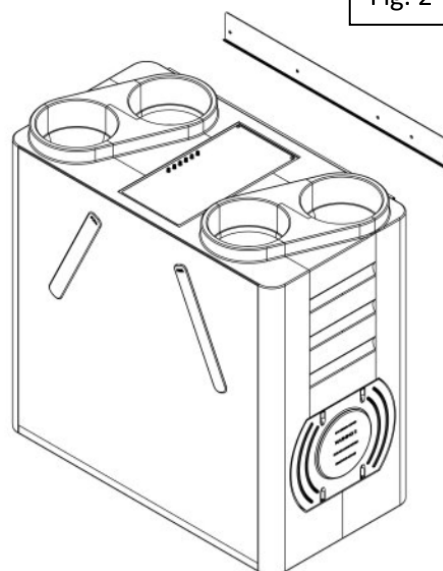

Fig. 3



## 4.12 CEILING MOUNT

The unit should be attached to the Ceiling as shown (Fig.1) by first fixing the bracket to the unit using the fixings provided.

The brackets can only be fitted to the unit in one way, the fixing holes are colour coded to help with fixing orientation. When the brackets have been fitted ensure that they are in the correct position as shown in Fig 1. Before mounting to the ceiling.

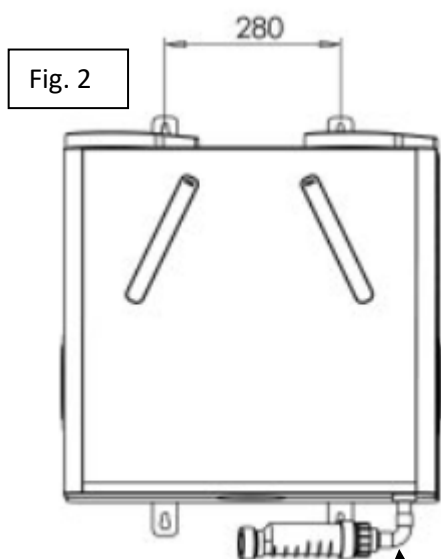
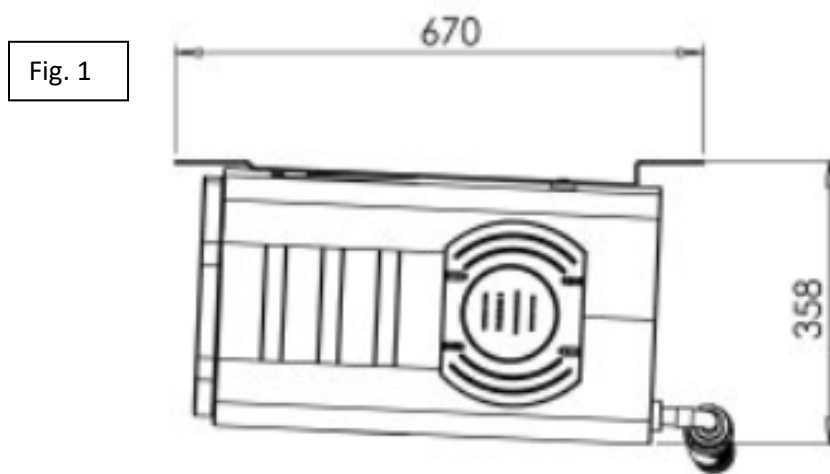

Brookvent supply drainage to this point.

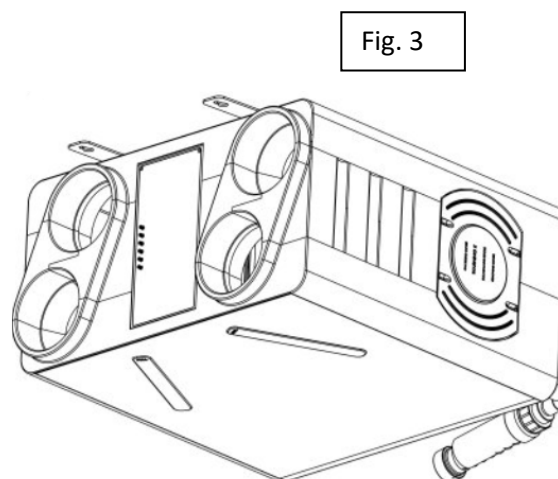

Dry Trap (Not Incl.) must be fitted with a minimum **10 degree fall**. Trap not included.

Also supplied are:

- **No.** – Ceiling Mounting Bracket (Quantity: 2)
- **No.5** – M8 Anti Vibration Washer (Quantity: 8)
- **No.3** – M8 x 30 Ceiling Anchor (Quantity: 4)
- **No.6** – M8 x 16 Socket Cap Bolt (Quantity: 8)
- **No.4** – M8 x 24 Washer (Quantity: 4)

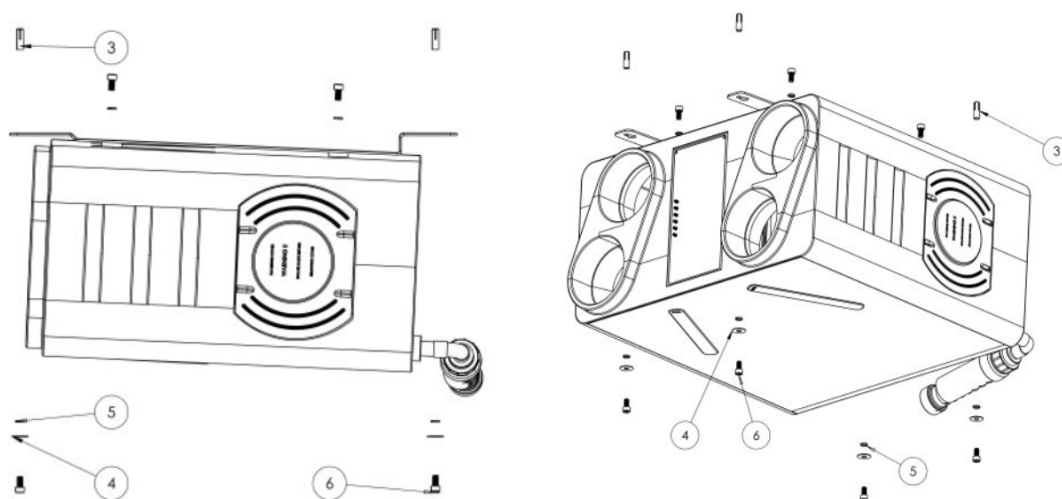

Please ensure that this method of fixing is suitable for the mounting surface and that it can safely bear the load.

#### 4.13 FLOOR MOUNT

The unit should be attached to the Floor as shown (Fig.1) by first fixing the bracket to the unit using the fixings provided.

The brackets can only be fitted to the unit in one way, the fixing holes are colour coded to help with fixing orientation. When the brackets have been fitted ensure that they are in the correct position as shown in Fig 1. Before mounting to the floor.

The unit should be attached to the Floor, as shown, mounted on a raised plinth. (Fig.1).

Fig. 1

NB. Dry trap (Not Incl.) must be fitted with a minimum **10 degree fall.**

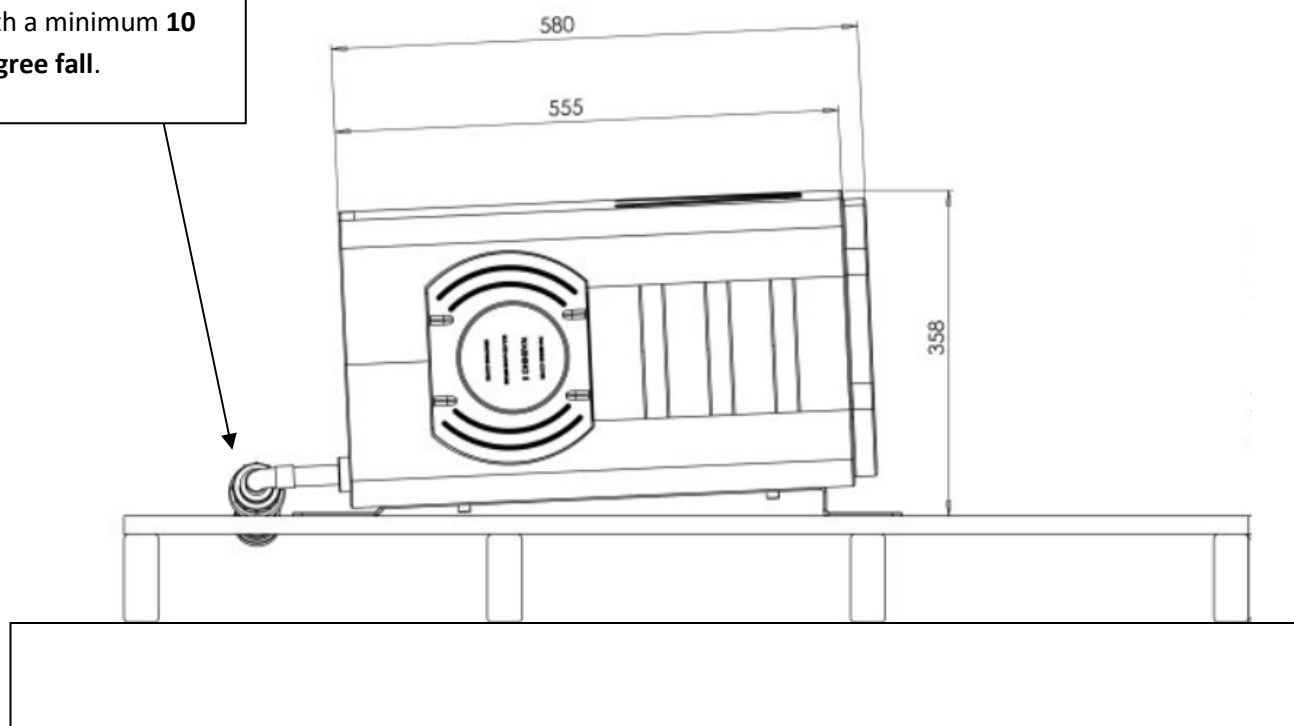

Please ensure that this method of fixing is suitable for the mounting surface and that it can safely bear the load.

## 4.2 Ductwork and Connections

To comply with SAP Appendix Q, and to facilitate the air flow performance, all ducting used should be rigid. If flexible ducting is required, it should be kept to an absolute minimum of 300mm and kept taut as per the Domestic Compliance Guide (Part F: Eng and Wales 2010).

The spigots on the Brookvent aircycle 1.3 systems are suitable for connection to 125mm diameter round pipe.

The label on top of the unit clearly identifies which spigot should be connected to which ducting route within the dwelling. This is also shown clearly within this manual.

For optimum efficiency and performance, it is recommended that 125mm diameter round pipe is used (where possible) to connect to the spigots and continue throughout the dwelling, this will assist in keeping pressure losses to a minimum. A minimum straight vertical run of 300mm should also be used directly off each spigot (where possible).

Where it is not possible to continue throughout the dwelling in rigid 125mm diameter round pipe due to the void spaces available, a conversion to rigid 204mm x 60mm flat rectangular ducting is recommended. It is recommended that the number of bends in the ducting system is kept to a minimum.

Each of the external roof terminals / wall terminals must be the equivalent to the open area of 125mm diameter round pipe.

To facilitate air circulation within the dwelling there must be a minimum of 10mm undercut on each of the doors (to the finished floor) within the dwelling (or grills placed at low level on the doors).

Extract air valves should be placed in all wet rooms (kitchen, utility, en-suite, etc.) and should be sited, where possible, close to the main source of humidity/ pollutant.

Fresh supply air valves should be placed in all habitable rooms (bedroom, living room, dining room, etc.).

Air valves should be locked upon commissioning so that they are tamper proof.

Duct designs/ layouts should always be adhered to if provided.

The Domestic Compliance Guide: Eng. and Wales 2010 or relevant equivalent dependent upon local guidelines, should be adhered to in terms of installation practices.

## 4.3 Connection of Condensate Drain

### 4.3.1 WALL MOUNT

HRV systems generate considerable amounts of moisture due to their high Heat Recovery Efficiency; this moisture must be drained from the system to a suitable discharge location.

The aircycle 1.3 is supplied complete with a centralised drainage connection on the bottom of the unit.

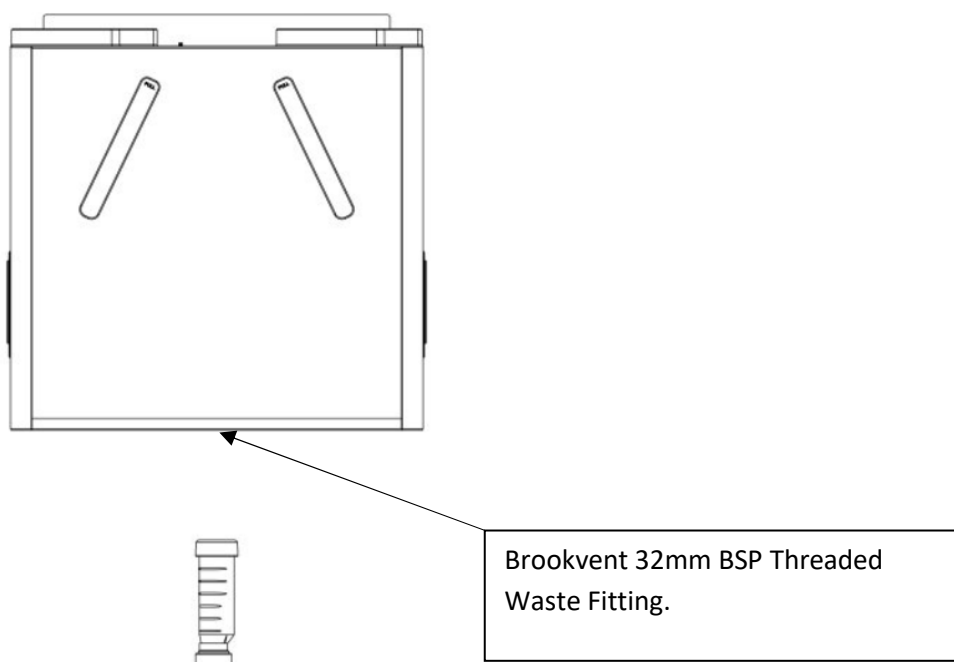

Brookvent recommend the use of a 32mm "Waterless Dry Trap" on HRV systems (as shown above) to prevent the back flow of air into the HRV unit from the waste discharge system.

It is imperative that there is a gravitational fall from the unit to the discharge point ensuring that the water drains from the unit. A minimum fall of **5 Degrees** should be ensured throughout. Drainage piping/ connections should be insulated if located in cold roof spaces. NB. Dry trap (Not Incl.) must be fitted with a **5 Degree** fall at that point.

Drainage piping/ connections should be insulated if located in cold roof spaces.

DO NOT connect other condensate pipes from the system or other systems BEFORE the "Waterless Dry Trap"

### 4.32 CEILING MOUNT

HRV systems generate considerable amounts of moisture due to their high Heat Recovery Efficiency; this moisture must be drained from the system to a suitable discharge location.

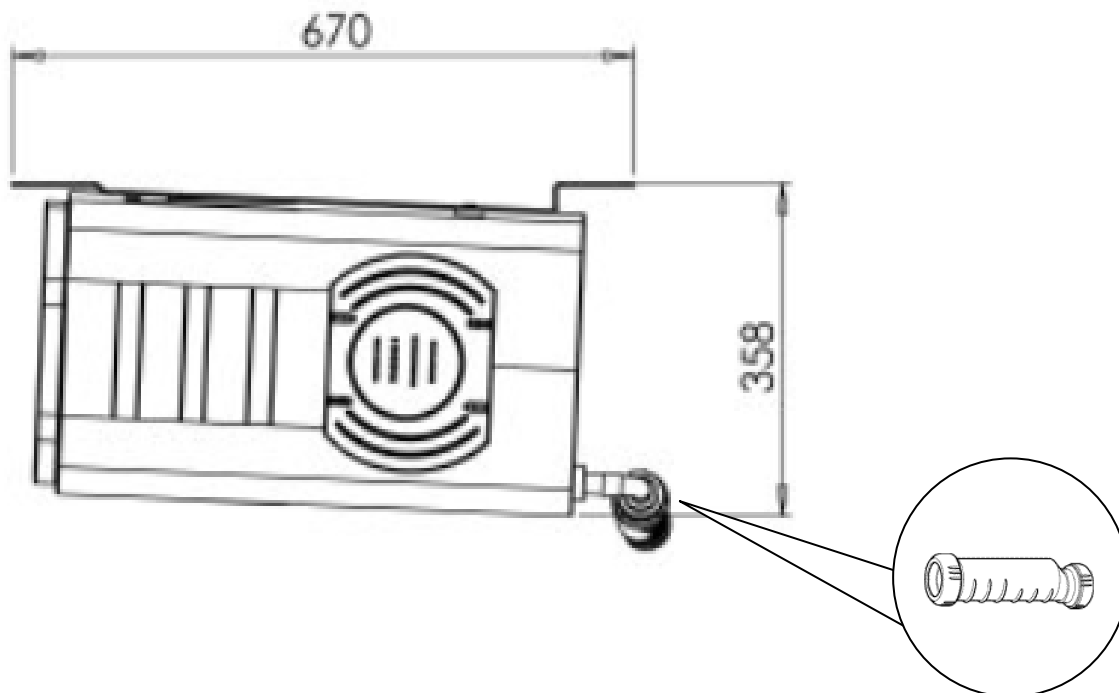

The aircycle 1.3 Ceiling mount drainage connection is **21.5mm**.

Brookvent recommend the use of a 32mm "Waterless Dry Trap" on HRV systems (as shown above) to prevent the back flow of air into the HRV unit from the waste discharge system.

It is imperative that there is a gravitational fall from the unit to the discharge point ensuring that the water drains from the unit. A minimum fall of **5 Degrees** should be ensured throughout. Drainage piping/ connections should be insulated if located in cold roof spaces. NB. Dry trap (Not Incl.) must be fitted with a minimum **10 Degree** fall at that point with a minimum of 5 degree fall in the condensate pipe thereafter.

Drainage piping/ connections should be insulated if located in cold roof spaces.

DO NOT connect other condensate pipes from the system or other systems BEFORE the "Waterless Dry Trap"

### 4.32 FLOOR MOUNT

HRV systems generate considerable amounts of moisture due to their high Heat Recovery Efficiency; this moisture must be drained from the system to a suitable discharge location.

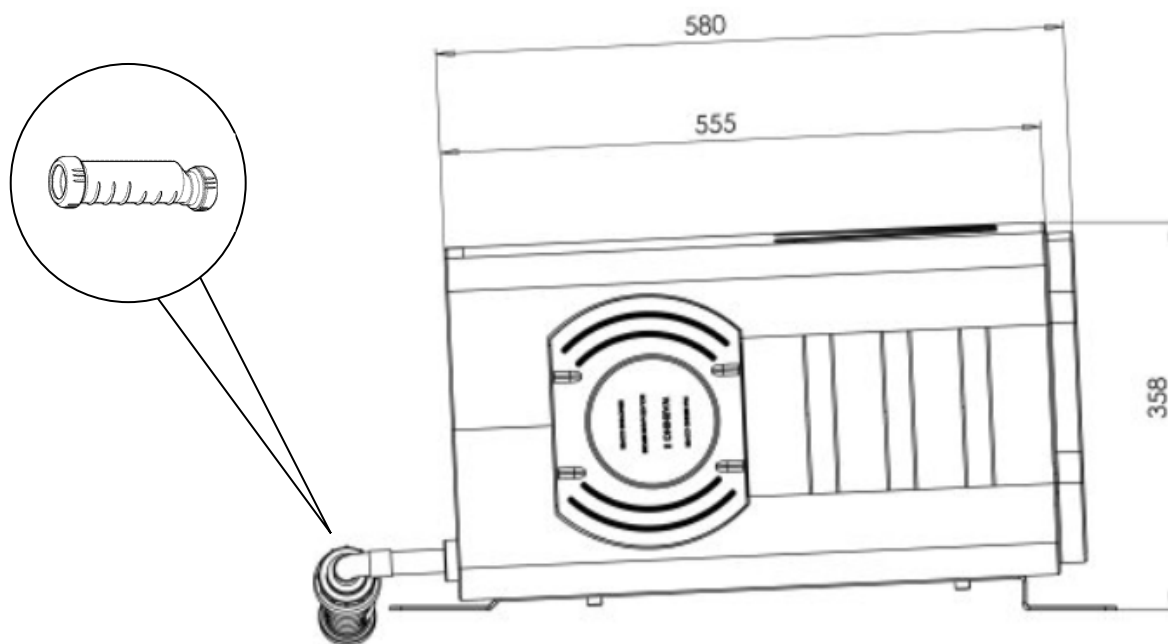

The aircycle 1.3 Floor mount drainage connection is **21.5mm**.

Brookvent recommend the use of a 32mm "Waterless Dry Trap" on HRV systems (as shown above) to prevent the back flow of air into the HRV unit from the waste discharge system.

It is imperative that there is a gravitational fall from the unit to the discharge point ensuring that the water drains from the unit. A minimum fall of **5 Degrees** should be ensured throughout. Drainage piping/ connections should be insulated if located in cold roof spaces. NB. Dry trap (Not Incl.) must be fitted with a minimum **10 Degree** fall at that point with a minimum of 5 degree fall in the condensate pipe thereafter.

Drainage piping/ connections should be insulated if located in cold roof spaces.

DO NOT connect other condensate pipes from the system or other systems BEFORE the "Waterless Dry Trap"

## 5.0 Electrical Connections/ Wiring

### IMPORTANT

All the electrical connections must be carried out by a qualified electrician. Installations and wiring must conform to current IEE regulations (UK), local or appropriate regulations (applying to other countries).

#### Electrical Details:



Voltage: 230 V AC ~

Fuse rating: 3 A

Warning: This unit must be earthed.

Please Note: The core cable from the mains power supply must be connected to a fixed wiring installation, via a **3 amp** fused isolator, as to comply with current IEE wiring regulations.

A switch or circuit breaker must be used in the power supply circuit. It should be in close proximity to the HRV unit and should be clearly marked as the disconnecting device for the HRV Unit.

#### Connecting to mains:

The aircycle 1.3 unit comes pre-wired with 2m length of 4-core cable, which should be connected into a fan-isolation switch. In turn a 3-core mains cable should be used to connect to a **3A fused spur**, which should be located close to the unit. The unit should never be connected to a plug outlet.

Green/Yellow	= Earth
Brown	= Live
Black	= Neutral
Grey	= Switch Live 1 (boost)
Black	= Switch Live 2 (purge)

The grey switch wire is used to boost the system. When a live 230v signal is applied, the Auto Boost function will be triggered.

## 5.1 Wiring Schematic

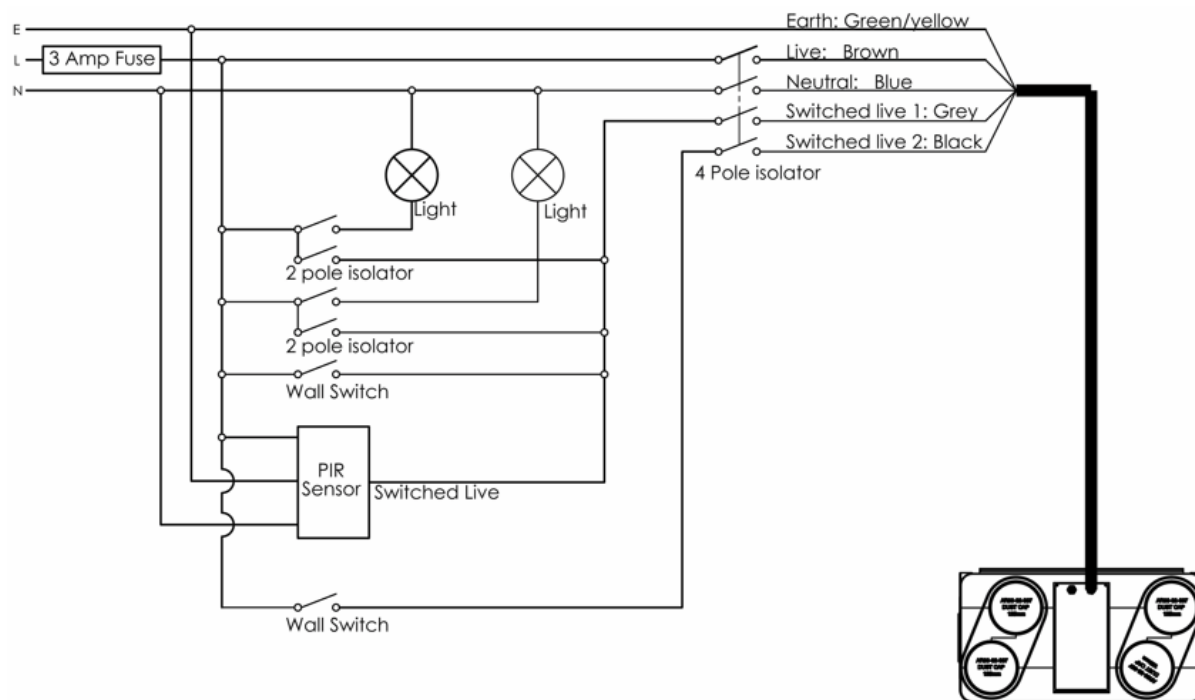

## 6.0 Controls and Settings

### 6.1 Fan Speed Control

The fan speeds of the unit are controlled by four potentiometers (Speed Pots) on top of the unit; these are clearly marked "Trickle" and "Boost". These allow individual control of the trickle and boost rates for the supply and extract fans within the unit.

These separate speed options allow one speed to be set for normal day to day operation (i.e. Trickle) and an increased speed to be set (i.e. Boost) that operates only when the Grey switch wire is triggered by a 230v boost signal such as a Wall Switch or Passive Infrared Sensor.

If the Boost for either fan is required to be set, it should always be set higher than the Trickle. Turning these Speed Pots clockwise increases the fan speed.

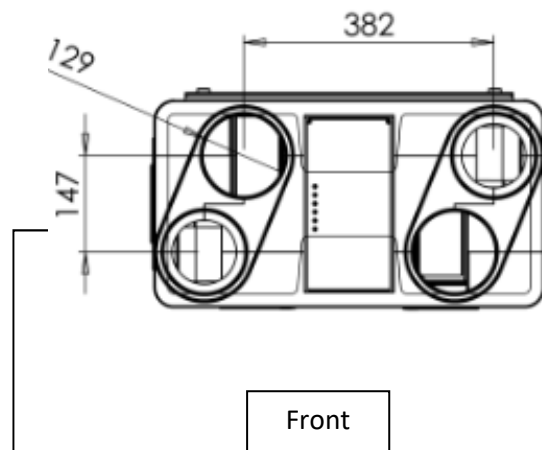
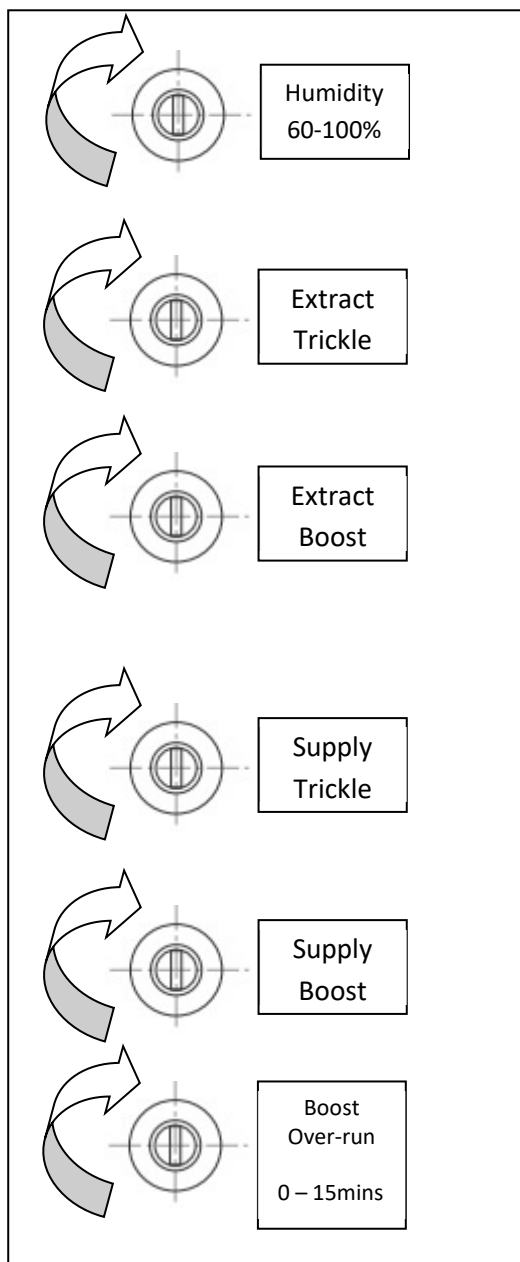

**NB.** On standard configuration systems the controls are located on the RHS as shown. Inverted configuration systems have their controls located on the LHS and are clearly labelled.

## 6.2 Commissioning Fan Speeds

1. Turn all 4 fan control spindles down fully to off (**Extract Trickle, Extract Boost, Supply Trickle, Supply Boost**).
2. Turn the "Boost Over-run" to zero.
3. Turn the Boost Switch on (or trigger the boost by other means provided, e.g. bathroom light switch relay if applicable).
4. Turn the **Extract Boost** spindle up until the minimum extract boost rate is achieved in all the wet rooms (extract valves) as per the BPEC process for commissioning.
5. Turn boost switch off (or other if applicable).
6. Turn the **Supply Trickle** up until the whole dwelling ventilation rate has been achieved in all the habitable rooms (supply valves) as per the BPEC process for commissioning.  
**NB:** The trickle rate cannot be higher than the boost rate.
7. Turn the **Extract Trickle** up until the total airflow balances the total supply trickle rate.  
**DO NOT ADJUST THE VALVES!**
8. Turn the Boost Switch on (or trigger the boost by other means provided, e.g. bathroom light switch relay if applicable).
9. Turn the **Supply Boost** up until the total airflow balances the total extract boost rate.  
**DO NOT ADJUST THE VALVES!**
10. Ensure that the whole system is commissioned correctly following the procedures laid out by BPEC and the Domestic Compliance Guide (England and Wales) – Part F – Means of Ventilation.

Commissioning is carried out to ensure that the required air flows are achieved throughout the property. The volume airflow at each point should be measured using a suitably calibrated Airflow Meter (anemometer), this should be fitted with an adapter/hood to ensure all air is captured and measured by the device.

For the required airflow rates refer to the design specification for the property and or refer to Building Regulations (Part F: Means of Ventilation, England and Wales) or relevant equivalent dependent upon local guidelines.

If further guidance is required on the commissioning process, please contact Brookvent directly.

**Example Commissioning:**Property – Area: 80m<sup>2</sup>Airtightness: less than 5m<sup>3</sup>/hr @ 50PaSupply Rooms:Extract Rooms

Living 11l/s

Kitchen 13l/s

Dining 5l/s

Bathroom 8 l/s

Bedroom 8 l/s

En-suite 8 l/s

Whole dwelling ventilation rate = 24l/s *(the greater of Area x 0.3 or whole dwelling rate table in building regulations).*

Whole dwelling boost rate =29 l/s *(the greater of the summation of the extract rates or the whole dwelling rate).*

As per the instructions above, turn all spindles down. Turn the boost switch on. Turn the Extract boost spindle up until the extract boost rates are achieved (kitchen 13l/s, bathroom 8l/s, En suite 8 l/s).

Lock the valves in place.

Turn the boost switch off. Turn the supply trickle spindle up to achieve the rates for the supply rooms (living 11l/s, Dining 5l/s, Bedroom 8l/s).

Lock the valves in place.

Turn the Extract up down until the whole dwelling rate i.e. 24l/s is achieved through the extract valves. Do not adjust the valves, only adjust the control on the unit.

Turn the boost switch on. Turn the Supply Boost up until the whole dwelling Boost rate i.e. 29l/s is achieved through the Supply valves. Do not adjust the valves, only adjust the control on the unit.

Turn the boost switch off.

## 6.3 Humidity Control

This potentiometer control is located on the front of the unit and can be adjusted by hand and can be set between 60%-100% (Not active) relative Humidity, causing the unit to boost when it senses the set humidity level. Adjusting the speed pot anti-clockwise will cause the unit to become more sensitive thus boosting the system more often.

**The factory setting for humidity is 70% RH.** Turning this Speed Pot clockwise increases the humidity level at which the unit will boost.

**NB.** Upon start-up/ power-on the humidity sensor will be inactive for a period of 60mins due to calibration.

## 6.4 Boost Over-Run Timer

All Brookvent aircycle systems come complete with an automatic boost over-run timer of 15mins (factory set). The grey 'switch wire' on the aircycle 1.3 systems (See section '5.0 Electrical Connections/ Wiring') is used to boost the system.

When a live 230v signal is applied by a switch or sensor, the boost function will be triggered. When the signal stops, the boost will over-run for a maximum of 15 mins as to ensure the system has adequately cleared the pollutants that were present. This is also true for the internal humidistat feature in the aircycle 1.3.

The 15min boost over-run timer control is located on the front of the unit and can be adjusted by hand and can be set between 0 mins and 15 mins by rotating the control clockwise to increase the over-run timing.

## 6.5 Frost Protection

This is an automatic factory setting that causes the supply fan to turn off for 5 minutes every hour when it senses temperatures below the 5 °C the set level allowing the warm extract air from the home to pass through the core unaccompanied by the cold fresh intake air. This action raises the overall temperature within the Heat Recovery System preventing the potential formation of ice particles which could cause damage.

**This feature is factory set, automatic, and requires no maintenance.**

## 6.6 Activated Summer Bypass

Feature available on selected models only (AS 90-0103-WINS-01).

This unit has been fitted with the activated summer bypass feature.

The activated summer-bypass, functions via thermostatically responsive solenoid which directs the air around the Heat Recovery Core as the temperature rises, thus comfortably regulating the indoor air temperature during warmer months.

The bypass is set to activate based on the internal and external conditions. The bypass will only activate when both conditions have been met.

The settings for bypass activation are 17°C external temperature and 21°C internal temperature. When the temperature of the fresh air being drawn in from outside exceeds 17°C AND the temperature of the extracted air from the house exceeds 21°C then the bypass will open. The bypass will close when either of two temperatures drops below the set levels.

**The activation temperatures are set in the software and cannot be changed.**

## 6.7 Purge Mode

Requires a separate switch or 230v signal. When activated this puts the unit to 100% fan power (factory set) to rapidly remove pollutants. It is intended that this feature is generally only used for short periods of time. therefore, Connection of this feature to a timed switch to avoid the unit being left in this mode should be considered.

## 7.0 Maintenance



**Warning:** Dangerous Voltage. Before completing any form of maintenance, ensure to isolate the unit from the mains and ensure all supply circuits are disconnected.

This HRV unit may contain connections/signal wires from multiple electrical circuits. **ISOLATING THE CONTROL BOX WILL NOT ISOLATE ALL CIRCUITS WITHIN THE UNIT- PLEASE ENSURE ISOLATION OF ALL CONNECTING CIRCUITS BEFORE ACCESSING THE UNIT.** Examples of other connecting circuits are: electric showers, lighting circuits, and humidistats. These connecting circuits may be used to trigger the auto-boost the system.

It is important to follow all guidelines relating to the maintenance of this HRV system to ensure the unit continues to perform to the levels required.

## 7.1 Filter Replacement

The filters of this HRV unit will usually need to be changed every 6 – 12 months depending on occupancy/ use, and the type of environment the dwelling is located in (i.e. urban/ rural, and their associated levels of airborne pollutants).

It is recommended that the filters are checked every 6 months. Replacement filters can be purchased online at [brookvent.co.uk](http://brookvent.co.uk)

To change the filters, simply remove the filter covers from the front of the unit, replace the filters, and replace the filter covers firmly.



**Important:** Blocked filters will shorten the life span of your fan and increase the energy consumption. Never run the HRV system without filters as this will allow unfiltered material to build up in the heat recovery core and connected ductwork. In new build properties it may be prudent to check/ change your filters after the first 3 months of occupancy depending on the amount of residual 'building dust' present within the property.

## 7.2 Heat Exchange Core Check (only select models)

The aircycle 1.3 heat recovery core is protected by 2 no. filters. As long as the filters are regularly changed as detailed in the previous section there should be no need to access the system's heat recovery core. However, should regular filter changes not be adhered to it may be advisable to access the system's heat recovery core, and where required, clear it of any debris that may have collected.

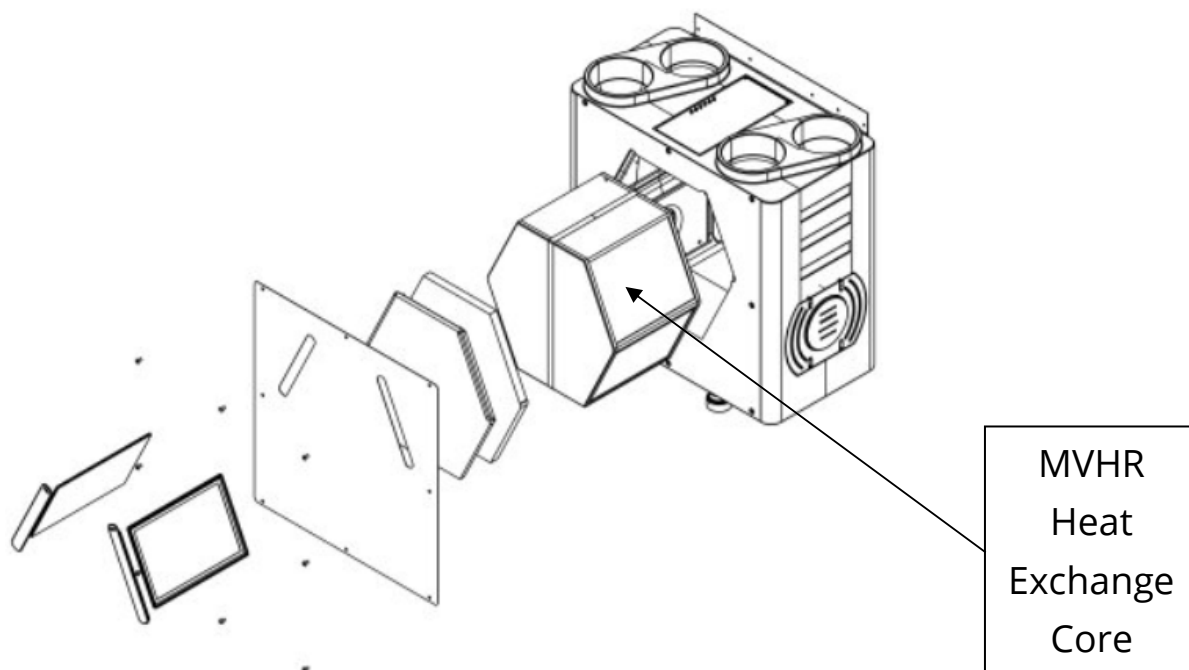

**Step 1.** Isolate the unit from the mains and ensure all supply circuits are disconnected. Never run the system with the MVHR heat exchange core removed.

**Step 2.** Remove both filters.

**Step 3.** Remove the front door panel via its 8 screws.

**Step 4.** Remove the foam panels and then the heat exchanger from the unit by pulling the plastic strip running across the front of the heat exchanger.

**Step 5.** Carefully remove any dust from the heat exchanger with a household vacuum cleaner. Do not attempt to clean the heat exchanger with any fluids.

**Step 6.** Carefully reinsert the heat exchange core into the unit and the foam panels.

**Step 7.** Reinsert both filters (change if necessary) and replace the front door ensuring all four screws are securely fastened. Also ensure the filter tabs on the front of the unit are securely fitted.

**Step 8.** Power the unit on at the isolator and ensure any supply circuits are reconnected.

## 7.3 Heat Exchange Core Check (Ceiling Mount)

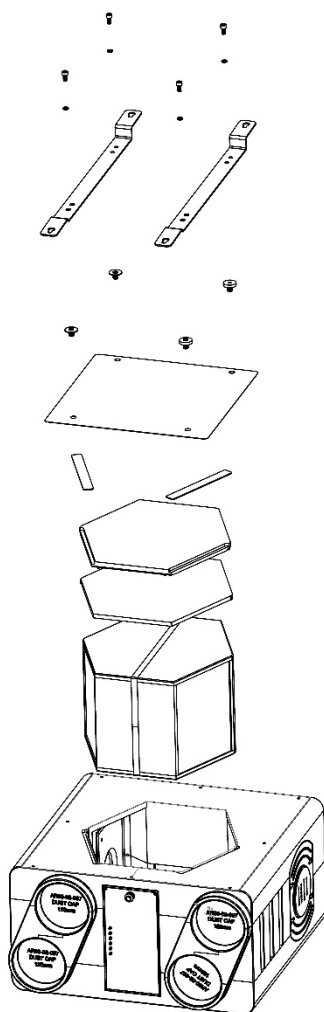

**Step 1.** Isolate the unit from the mains and ensure all supply circuits are disconnected. Never run the with the MVHR heat exchange core removed.

**Step 2.** Remove the unit from the ceiling by unscrewing the ceiling bracket from the ceiling.

This may require that the mains cable be disconnected if there is not enough length. This should only be done by a fully qualified person.

**Step 3.** Unscrew the 4 fixings that hold the ceiling mount bracket to the unit (an adjustable wrench may be required to remove these).

**Step 4.** Remove the brackets and the back panel.

**Step 5.** Remove the foam panels and then the heat exchanger from the unit by plastic strip running in front of the heat exchanger.

**Step 6.** Carefully remove any dust from the heat exchanger with a household vacuum cleaner. Do not attempt to clean the heat exchanger with any fluids.

**Step 7.** Carefully re-insert the heat exchanger and the foam panels into the unit.

**Step 8.** Place the back panel on the unit so that the 4 holes line up with the threaded inserts and then place the bracket over the back panel again lining up the holes.

**Step 9.** Securely fit the 4 bracket fixings.

**Step 10.** Securely fit the unit back on to the ceiling.

**Step 11.** re-connect the power supply to the unit (if required). Power the unit on at the isolator and ensure that the unit starts up and is running normally.

## 7.4 Fan Replacement

The aircycle 1.3 heat recovery system has a very straight forward fan replacement process should the unlikely event of a fan failure occur.

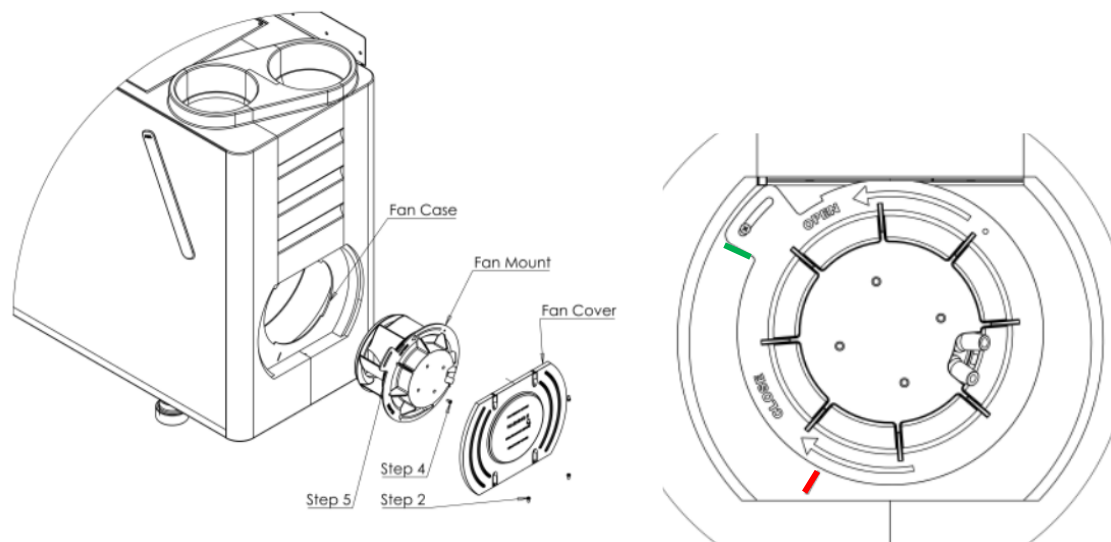

Turn Fan mount until the edge shown in green lines up with the line on the fan case (shown in red)

**Step 1.** Isolate the unit from the mains and ensure all supply circuits are disconnected.

**Step 2.** Unscrew the Fan cover (4 No. screws) and remove the cover.

**Step 3.** Unplug the two leads from the fan.

**Step 4.** Unscrew the locking screw on the fan mount.

**Step 5.** Turn the fan mount anti-clockwise to the line marked on the fan case and then pull straight out.

**Step 6.** Place the new fan assembly in the fan case, lining it up with the line marked in the fan case. Push inward until flush with the fan case and then turn clockwise to tighten.

**Step 7.** Refit the locking screw and connect the cables

**Step 8.** Re-fit the fan cover and secure with the screws.

**Step 9.** Power the unit on at the isolator and ensure any supply circuits are reconnected. The unit will not need to be re-commissioned as the controller will hold the settings.

## 7.5 Sensor Replacement

Replacement of the aircycle 1.3's temperature sensor and/or humidity sensor is also very straight forward in the unlikely event of a failure occurring.

### 7.5.1 Temperature Sensor Replacement

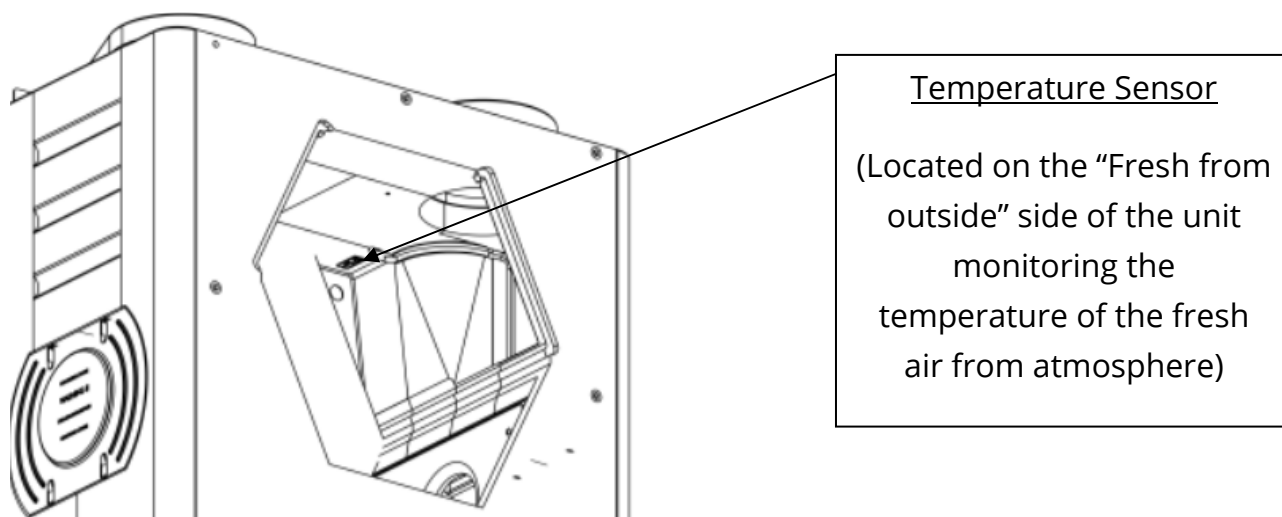

**Step 1.** Isolate the unit from the mains and ensure all supply circuits are disconnected.

**Step 2.** Remove both filters.

**Step 3.** Remove the front door panel via its 8 screws.

**Step 4.** Remove the sealing Foam and then the heat exchanger from the unit by pulling the plastic strip running across the front of the heat exchanger.

**Step 5.** Unplug the old sensor and return it to Brookvent. Plug the new sensor in place and screw it to the case (care should be taken when handling the new sensor, to avoid Electro static discharge damaging the sensor, ensure you are earthed when handling).

**Step 6.** Carefully reinsert the heat exchange core into the unit and replace the sealing foam.

**Step 7.** Replace the front foam panel.

**Step 8.** Reinsert both filters (change if necessary) and replace the front door ensuring all eight screws are securely fastened. Also ensure the filter tabs on the front of the unit are securely fitted.

**Step 9.** Power the unit on at the isolator and ensure any supply circuits are reconnected.

## 7.5.2 Humidity Sensor Replacement

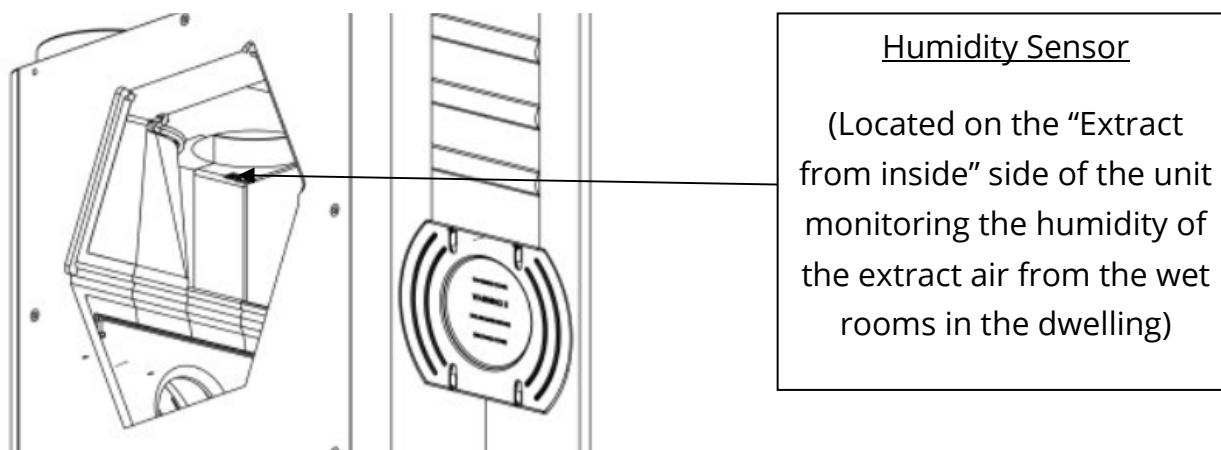

**Step 1.** Isolate the unit from the mains and ensure all supply circuits are disconnected.

**Step 2.** Remove both filters.

**Step 3.** Remove the front door panel via its 8 screws.

**Step 4.** Remove the sealing Foam and then the heat exchanger from the unit by pulling the plastic strip running across the front of the heat exchanger.

**Step 5.** Plug the new sensor in place and screw it to the case (care should be taken when handling the new sensor, to avoid Electro static discharge damaging the sensor, ensure you are earthed when handling).

**Step 6.** Carefully reinsert the heat exchange core into the unit and replace the sealing foam.

**Step 7.** Replace the front door panel via its 8 screws.

**Step 8.** Reinsert both filters (change if necessary) and replace the front door ensuring all four screws are securely fastened. Also ensure the filter tabs on the front of the unit are securely fitted.

**Step 9.** Power the unit on at the isolator and ensure any supply circuits are reconnected.

## 7.6 PCB Module Replacement

In the unlikely event of an electronic PCB failure, the Aircycle 1.3's PCB module can be disconnected and replaced.

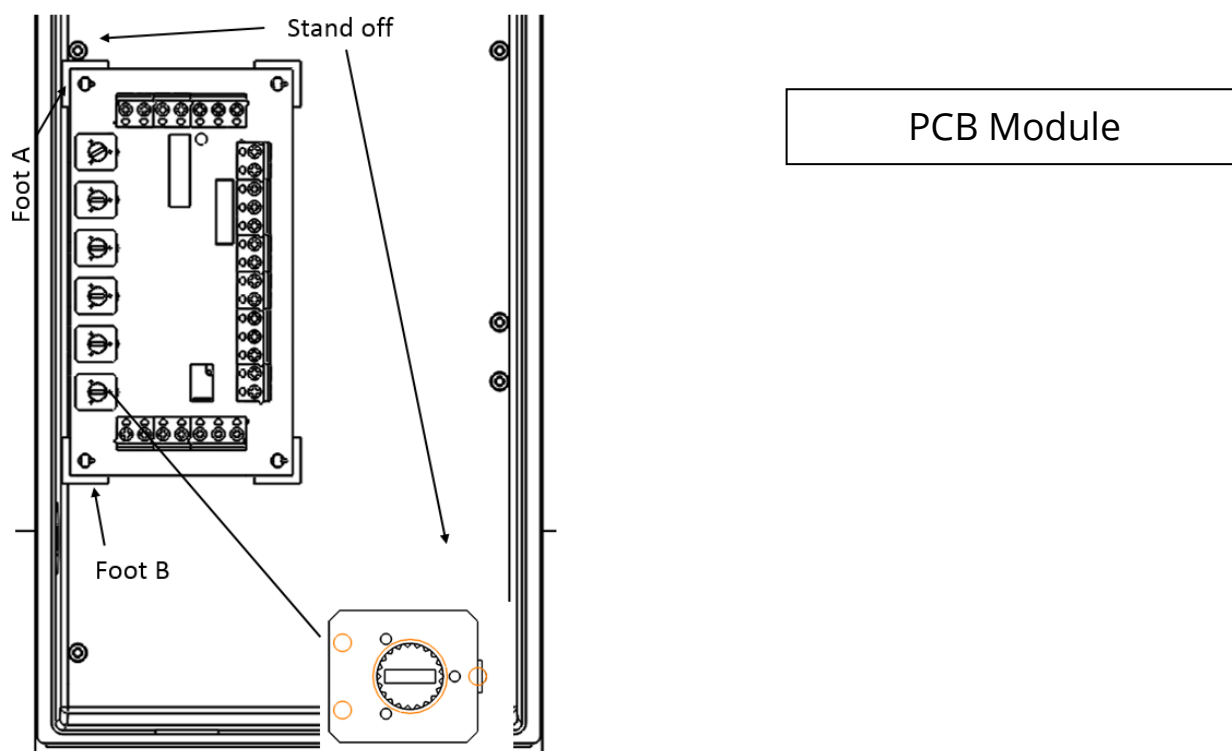

- Step 1.** PCB replacement should only be completed by a qualified Electrician.
- Step 2.** Ensure all circuits are isolated before working on the unit.
- Step 3.** When handling the PCB's ensure the devices are grounded to prevent electrostatic discharge from damaging the components.
- Step 4.** To locate the PCB in the correct position; line the **feet A & B** on the PCB along the edge of the enclosure as shown.
- Step 5.** Also line the edge of **foot A** shown against the yellow stand-off in the enclosure.
- Step 6.** This will ensure that the spindles line up with the holes in the enclosure lid.
- Step 7.** For inverted units (white label) line foot A up with the opposite edge and with the yellow stand off on the bottom right (i.e. the same position as the one being replaced).
- Step 8.** Wire the PCB as shown on the replacement documentation (note there are two sensors wired in the interface terminal, the unit may not work if only one is wired).
- Step 9.** When the unit is wired and fixed in place; insert the spindles in the potentiometers.
- Step 10.** To do this ensure all the potentiometers are turned fully anti-clockwise.
- Step 11.** Insert the spindles with the slot in the direction shown.
- Step 12.** Replace the cover and screw it in place.
- Step 13.** Re-connect the power.
- Step 14.** Recommission the system.

## 7.7 Additional Maintenance Checks

It is recommended that the following checks are also made when completing annual maintenance of the HRV unit:

- Condensate Drain: Ensure the condensation drain is firmly secured and is clear of any debris, remove/ clean if necessary.
- Fixings: Ensure that all of the unit fixings and the mounting fixings have not become loose over time and are kept sufficiently tight.

## 8.0 User Operation

The Brookvent aircycle 1.3 is an extremely compact and highly efficient Mechanical Heat Recovery Ventilation (HRV/MHRV) system, specifically designed for smaller dwellings and apartments with restricted space.

The system should be run continuously 24 hours a day, and should only be disconnected by a competent person during service or maintenance.

The system works by drawing stale air from 'wet rooms' such as Bathrooms, WC's and Kitchens, recovering up to **92%** of the heat from this air using a highly efficient heat exchanger, before expelling the waste air outside the home. Simultaneously, fresh air is drawn into the home, filtered and warmed by the recovered heat and supplied into the 'habitable rooms' such as bedrooms, dining rooms and living rooms.

How your system is configured upon installation will influence how it can be operated at the user level. Please ensure to refer to the commissioning certificate provided by your installer for full details.

### General Guidance

Your system may be set up to boost from trickle speed automatically via sensors (e.g. Passive Infrared Sensors) or manually via simple switch controls. These may be timed switches or push/pull switches. Boost options, if provided and if required, should be used when excess pollutants are being generated within the home (Cooking, Bathing etc.)

With certain dwellings the system may be configured to operate at what is known as a “constant ventilation rate”. This means that there is no boost required to adequately ventilate the home and the system operates at one set level at all times requiring no user input/control.

## 8.1 Typical Automatic Control Options

**Your system commissioning certificate completed by your system installer should detail your automatic control options (if any).**

### **Passive Infra-red (PIR) Sensors**

These are motion sensing switches; these sensors trigger the system into boost mode when activity/ motion is detected in a particular room. They are typically put into sanitary accommodation or bathrooms.

### **Humidistat**

These sensors detect humidity in the air and trigger the system into boost mode when humidity reaches a certain level. These are typically placed in bathrooms or in kitchens. Please note that the aircycle 1.3 system has an In-built humidistat that operates in the same fashion.

### **Light switch**

The lighting circuit of the home can be used to boost the system meaning that when the occupier enters the room and turns the on the light, the system is triggered into boost mode. This is typically used in sanitary accommodation and bathrooms. (note a double pole light switch is required when used to operate the boost function).

\*The items detailed above are examples of the types of Automatic Control Options that are typically used in conjunction with the Brookvent aircycle 1.3\*

## 8.2 Typical Manual Control Options

**Your system commissioning certificate completed by your system installer should detail your manual control options (if any).**

### **Spring loaded switch**

This switch may be placed in any room within the house; however, it is typically used in sanitary accommodation, bathrooms and or kitchens. When pressed, it will trigger the system into boost mode for a defined time.

### **Trickle and Boost switch**

This is a simple on-off switch with no determined time delay. When the switch is flicked to boost the system goes into its boost state, the switch then must be put back to trickle by the occupier for standard operation. (Please note that the aircycle 1.3 system has a minimum boost overrun time of 15mins).

\*The items detailed above are examples of the types of Manual Control Options that are typically used in conjunction with the Brookvent aircycle 1.3 \*

## 9.0 Trouble Shooting

### **The unit is not running?**

Check that the unit is connected to a 3amp fused spur.

Check that there is a live feed to the fused spur.

Check that the 3 amp fuse has not tripped/blown.

Check that all the spindles are in the full power position (the fans take a few seconds to start up).

Fan Failure indicator is illuminated (Selected models only) – See section 6.7 of this manual.

### **The system is constantly in Boost?**

New houses can be quite damp with items drying out; this can cause the inbuilt humidistat (and external humidistats) to activate. The in-built humidistat is disabled for the first hour after set up; however, if the system is boosting after this period the level can be adjusted to 100% effectively switching off the humidistat. Remember to turn this stat down again after commissioning.

Check whether the system is designed to boost from a light switch or relay, if so, have any of these been left on while commissioning process is being carried out.



## Notes

---

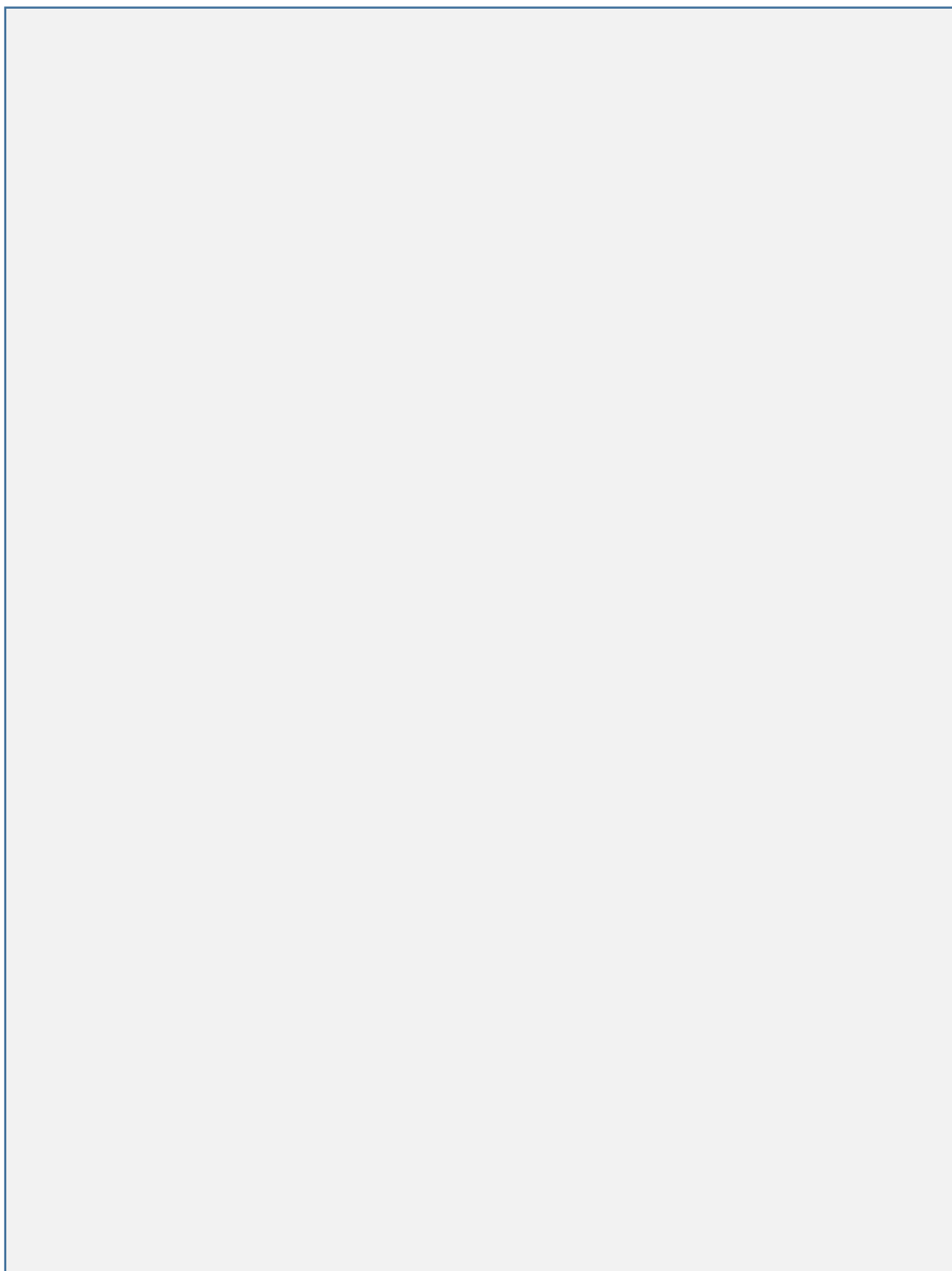

## Customer Support

Please feel free to contact one of our specialist team about any query you may have and we will be more than happy to assist you.

Brookvent  
Brook House,  
Dunmurry Industrial Estate,  
Dunmurry,  
Belfast  
Northern Ireland, BT17 9HU

T: +44 (0) 28 9061 6505

---

It is important to retain this manual and make a copy available to any person using or working with (maintaining) the system.

Brookvent operate a policy of continuous innovation and improvement and thus reserve the right to alter product specifications and appearances without notice.

