

BROOKVENT

airvent



SM 1400



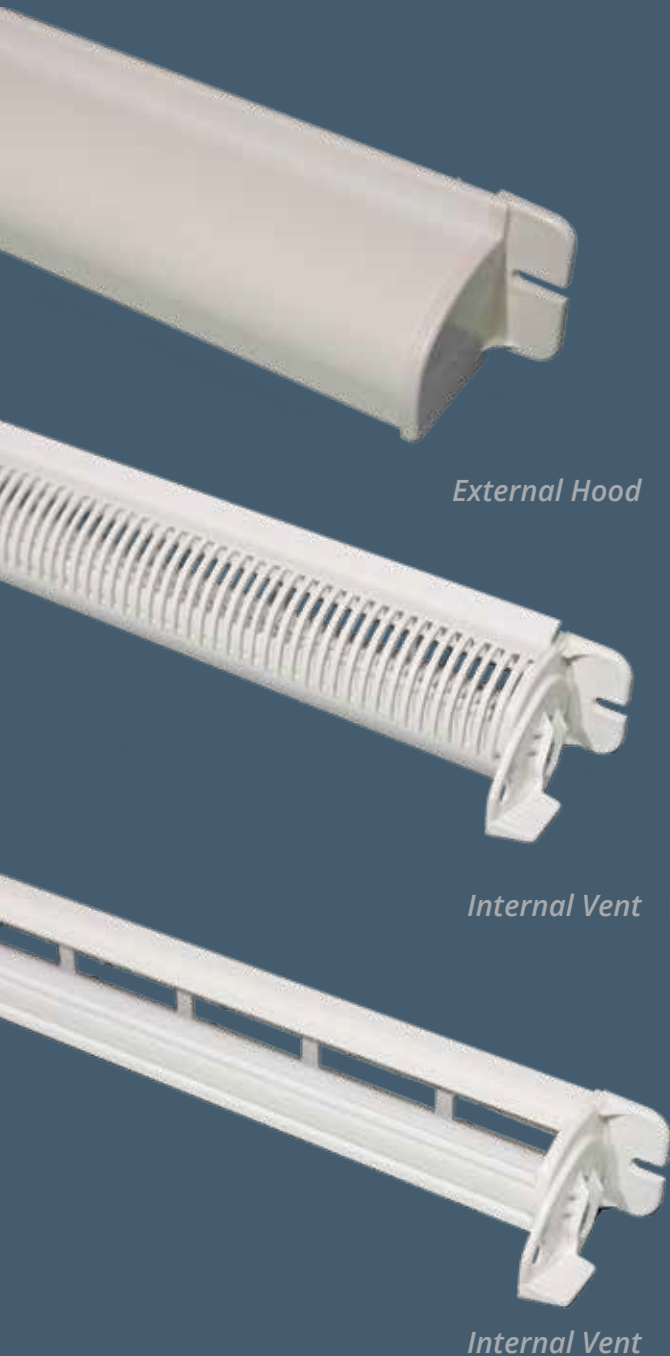

A severe weather rated Surface Mounted vent complete with wool pile seals. Ideal for high-rise buildings



Features

- Wool pile seals
- Insect grille
- Natural upward deflection
- Manufactured from extruded aluminium
- Polyester powder coated
- Fully controllable ventilation
- 10 Year Guarantee

Options

-  Manual Control
-  Rod control (Portable) 0.5m/1m
-  Bespoke Sizes
-  Bar Length
-  Internal removable grille
Available in white and black
(ease of cleaning in high rise projects)

Colours

-  White (HIPCA) RAL 9910 "Semi-gloss"
-  Mill Finish

Bespoke Colours and Finishes Available

Acoustics

Under normal conditions the airvent SM 1400 achieved the following Sound Reduction results:

Position	Acoustic Detail
OPEN	Up to 32 db Dne W
CLOSED	Up to 39 db Dne W

Acoustic test data available upon request

Bar Length

Internal vent 2.4m / External hood 2.4m

Modular Sizes

Geometric Open Area	Equivalent Area	Overall Slot Size	Overall Vent Length	Overall Hood Length
2296mm²	1575mm ²	16mm x 160mm	200mm	200mm
2996mm²	2200mm ²	16mm x 210mm	250mm	250mm
3696mm²	2825mm ²	16mm x 260mm	300mm	300mm
4396mm²	3450mm ²	16mm x 310mm	350mm	350mm
5096mm²	4075mm ²	16mm x 360mm	400mm	400mm
5796mm²	4700mm ²	16mm x 410mm	450mm	450mm
6496mm²	5325mm ²	16mm x 460mm	500mm	500mm
7196mm²	5950mm ²	16mm x 510mm	550mm	550mm
7896mm²	6575mm ²	16mm x 560mm	600mm	600mm
8596mm²	7200mm ²	16mm x 610mm	650mm	650mm
9296mm²	7825mm ²	16mm x 660mm	700mm	700mm

☰ Bespoke sizes available

Air Permeability

50 Pa 0.3 l/s (Closed Position)

Tested to BS EN 13141-1

Water Tightness

Pressure @ No Leakage 1000 Pa

Tested to BS EN 13141-1

Cross Section Dimensions

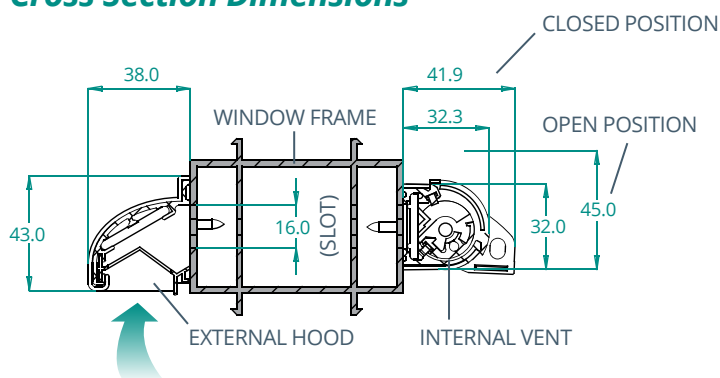

Dimensions in mm



air window ventilation range